



US DRAFT CO.

A Division of R.M. Manifold Group, Inc.

Boiler Venting

Definitions, Theory and Applications

Presented by:
Jason Geagan, National Sales Manager
US Draft Co
Fort Worth, TX



Gas Appliance Listings

- ANSI Z21 - Categorized Appliances
Gas fired low pressure steam and hot water boilers
- UL795 - Building Heating Appliances
Commercial-Industrial Gas Heating Appliances

Gas Appliance Listings

Definitions

- 3.3.80* Gas Appliance Categories. Vented gas appliances are classified for venting purposes into four categories as follows:
- (1) Category I – An appliance that operates with a non-positive vent static pressure and with a vent gas temperature that avoids excessive condensate production in the vent
 - (2) Category II – An appliance that operates with a non-positive vent static pressure and with a vent gas temperature that may cause excessive condensate production in the vent
 - (3) Category III – An appliance that operates with a positive vent static pressure and with a vent gas temperature that avoids excessive condensate production in the vent
 - (4) Category IV – An appliance that operates with a positive vent static pressure and with a vent gas temperature that may cause excessive condensate production in the vent.

A.3.3.80 Gas Appliance Categories. For additional information on appliance categorization, see the appropriate Z21 and Z83 American National Standards.

ANSI Z223.1 - Venting Categories

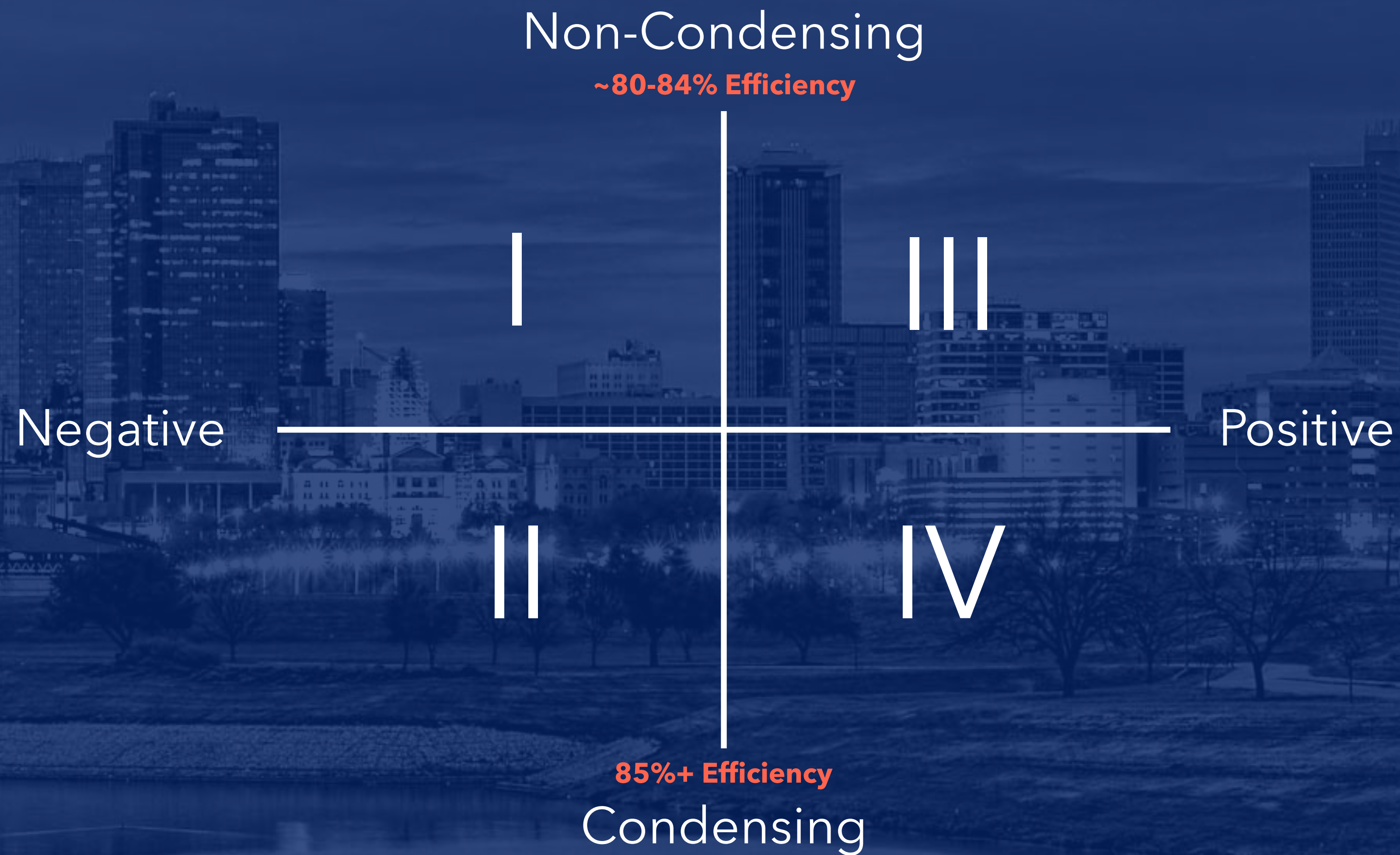

ANSI Z223.1 - Venting Categories

Type 'B' Gas Vent is the most common venting material for Category I Appliances

Specification:
UL-441 B-Vent

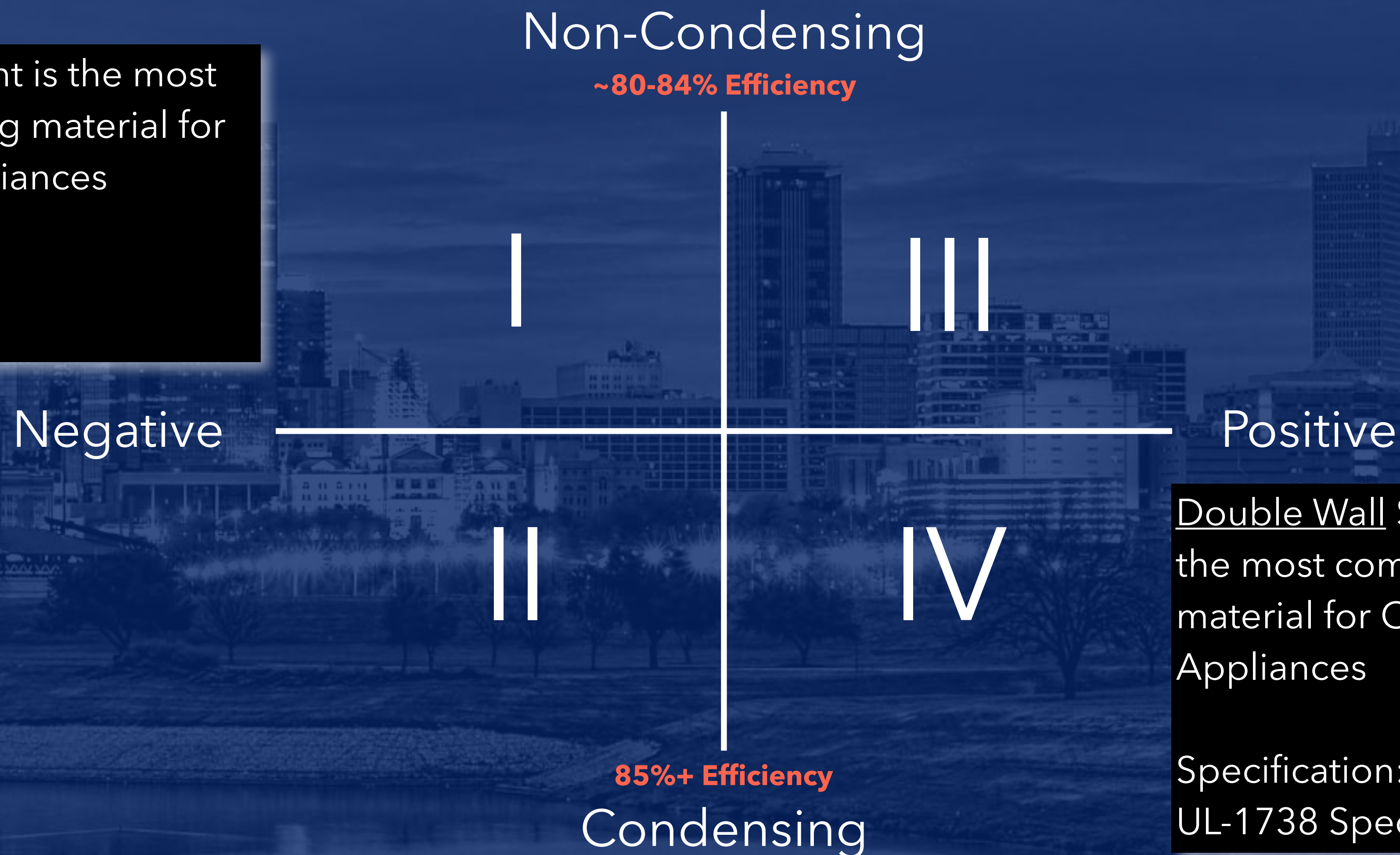

Double Wall Special Gas Vent is the most common venting material for Category II, III & IV Appliances

Specification:
UL-1738 Special Gas Vent

Using PVC to Vent Flue Gases

At present there is little data available on the safety or durability of plastic pipe products used to vent combustion gases. The ASTM has not addressed this application, and the available data is insufficient for the plastic pipe and fitting industry to develop consensus specifications or guidelines. Equipment manufacturers are most knowledgeable about their own products and are best-equipped to determine how their gas-fired heating equipment should be vented. Accordingly, [REDACTED] recommends that inquiries about the suitability of plastic piping systems to vent combustion gasses be directed to the manufacturer of the water or space heating equipment being installed.

UL795 - NFPA 211 Appliances

Definitions

3.3.3.6 *Nonresidential Appliance, 1400°F.* A commercial, industrial, or institutional appliance needing a chimney capable of withstanding a continuous flue gas temperature not exceeding 1400°F (760°C).

3.3.3.8 *Nonresidential, Low-Heat Appliance.* A commercial, industrial, or institutional appliance needing a chimney capable of withstanding a continuous flue gas temperature not exceeding 1000°F (538°C).

UL103 Pressure Tested Chimney



304SS or 316SS inner wall
Galvalum/Aluminized, 304SS or 316SS outer wall
Pressure tested up to 60"WC
1" air to 4" fiber insulation



Sizing Gas Appliance Vents

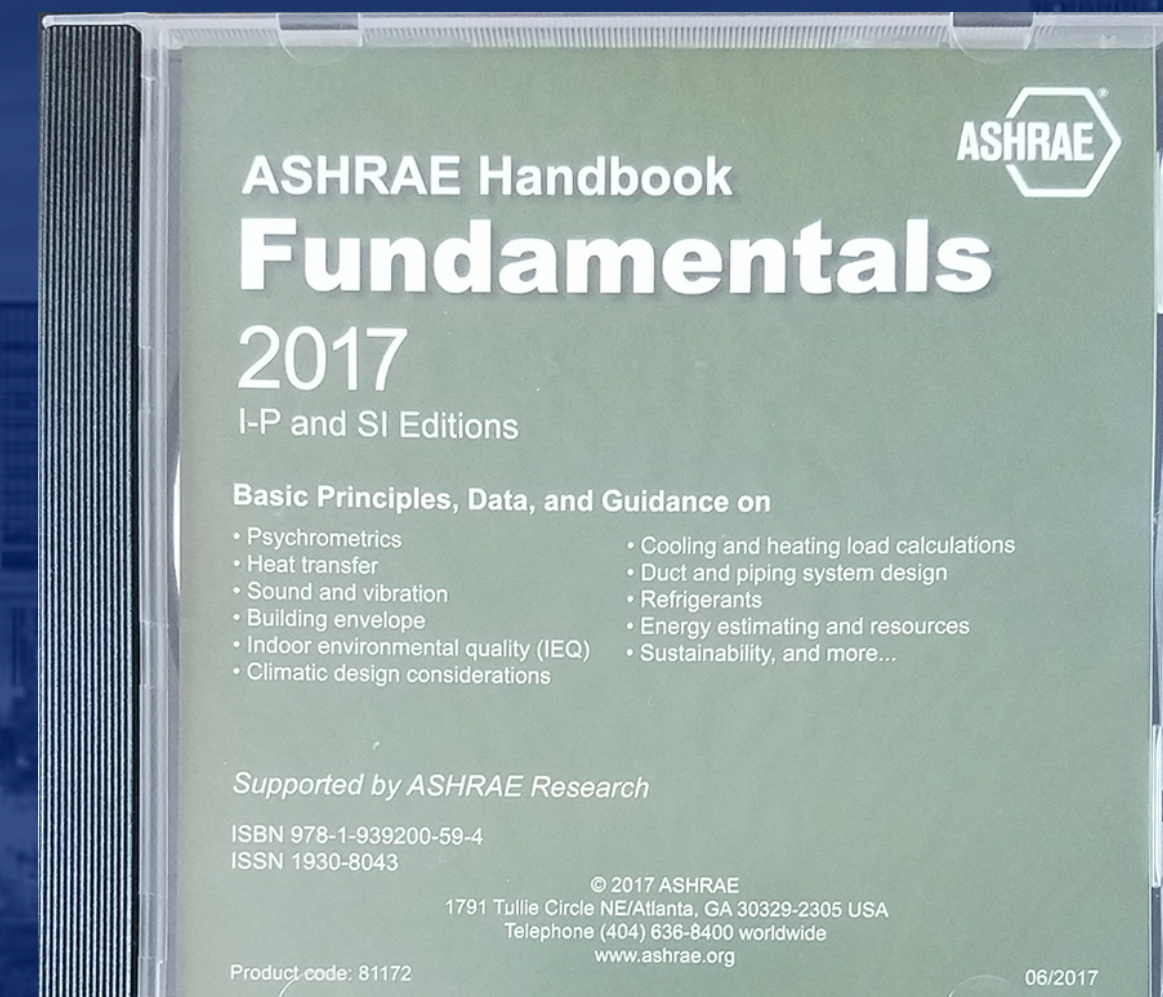
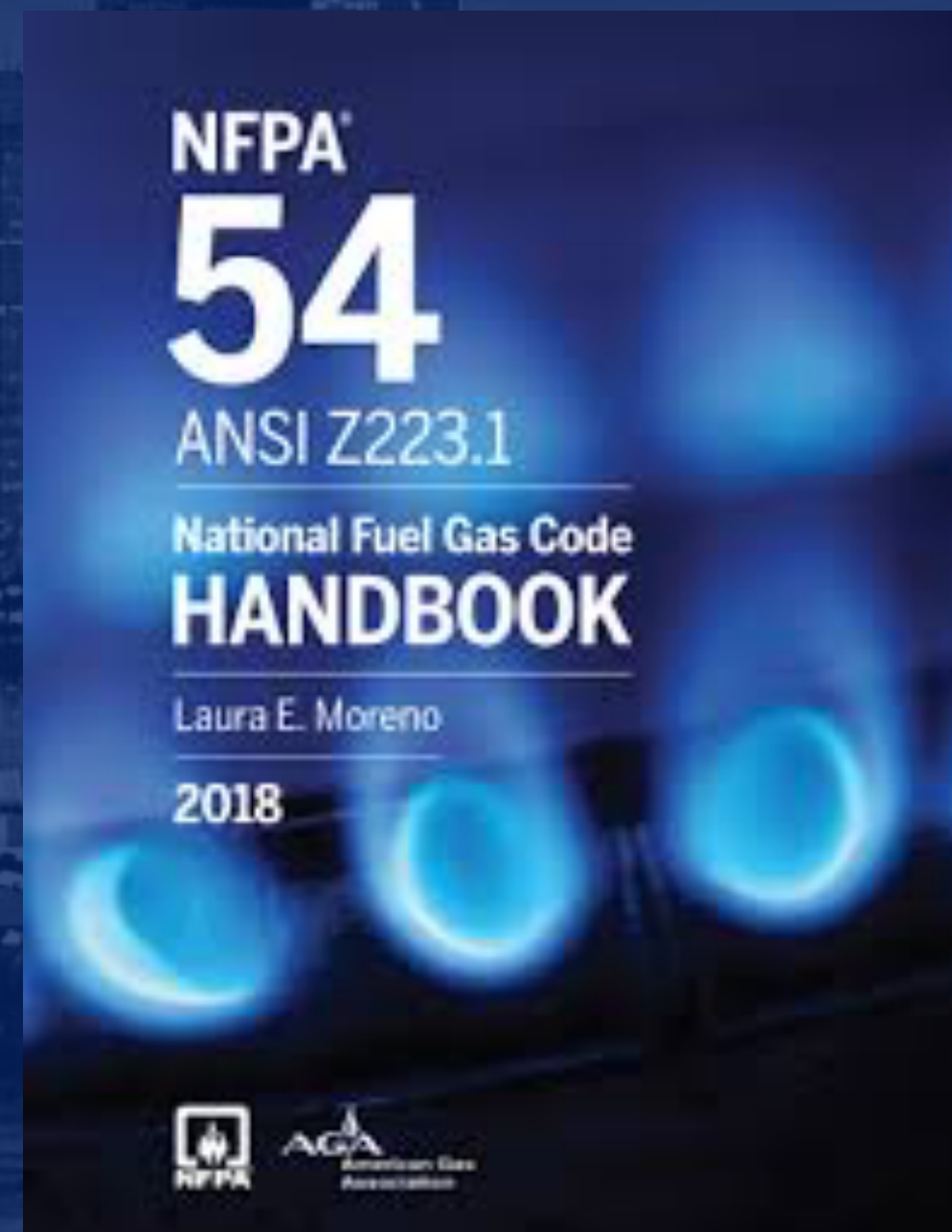

ASHRAE Chimney Design Equation

The equations and design chart may be used to determine the vent or chimney size based on **steady-state** operating conditions

$$I = 4.13 \times 10^5 (d_i^2 / M) (\Delta p T_m / kB)^{0.5}$$

I = Input, Btu/h

d_i = Inside Diameter, in.

M = Ratio of Mass Flow to Heat Input

Δp = Pressure Loss, "w.c.

T_m = Mean Flue Gas Temperature, °R

k = Resistance Coefficients

B = Barometric Pressure, inHg

ASHRAE Chimney Design Equation

The equations and design chart may be used to determine the vent or chimney size based on **steady-state** operating conditions

$$I = 4.13 \times 10^5 (d_i^2 / M) (\Delta p T_m / kB)^{0.5}$$

I = Input, Btu/h

d_i = Inside Diameter, in.

M = Ratio of Mass Flow to Heat Input

Δp = Pressure Loss, "w.c.

T_m = Mean Flue Gas Temperature, °R

k = Resistance Coefficients

B = Barometric Pressure, inHg

Does not consider modulation, cycling, or time to achieve equilibrium flow conditions from a cold start

ASHRAE Equation Determine Pressure Loss

Determine the Pressure Loss

$$\Delta p = (k \rho_m V^2) / 10.4g$$

Δp = Pressure Loss, "WC

k = Total System Resistance

ρ_m = Gas Density, lb/ft³

V = Gas Velocity, FPS

g = gravity, 32.174 ft/s²

Pressure losses are directly proportional to the resistance factor and to the square of the velocity.

ASHRAE Equation Determine Pressure Loss

Determine the Theoretical Draft

$$D_t = 0.2554BH(1/T_o - 1/T_m)$$

D_t = Theoretical Draft, "WC

B = Barometric Pressure, inHg

T_o = Ambient Temperature, °R

T_m = Mean Flue Gas Temperature, °R

H = Height of the Chimney, ft

Theoretical draft increases directly with height and the difference between ambient and flue gas temperatures

ASHRAE Equation Determine Pressure Loss

Determine the Theoretical Draft

$$0.098'' \text{ wc} = 0.2554(29.92)(20)((1/520)-(1/780))$$

Determine the Theoretical Draft

$$0.079'' \text{ wc} = 0.2554(29.92)(20)((1/520)-(1/710))$$

Determine the Theoretical Draft

$$0.039'' \text{ wc} = 0.2554(29.92)(20)((1/520)-(1/600))$$

Theoretical draft increases directly with height and the difference between ambient and flue gas temperatures

Effect of Chimney Height vs Outdoor Temp

| Height | 105°F | 60°F | 0°F |
|--------|-----------------|-----------------|-----------------|
| 5' | -.017"WC | -.0233"WC | -.032"WC |
| 20' | -.069"WC | -.093"WC | -.131"WC |
| 50' | -.17"WC | -.233"WC | -.320"WC |

@ 300°F Flue Gas Temp., 500' ASL

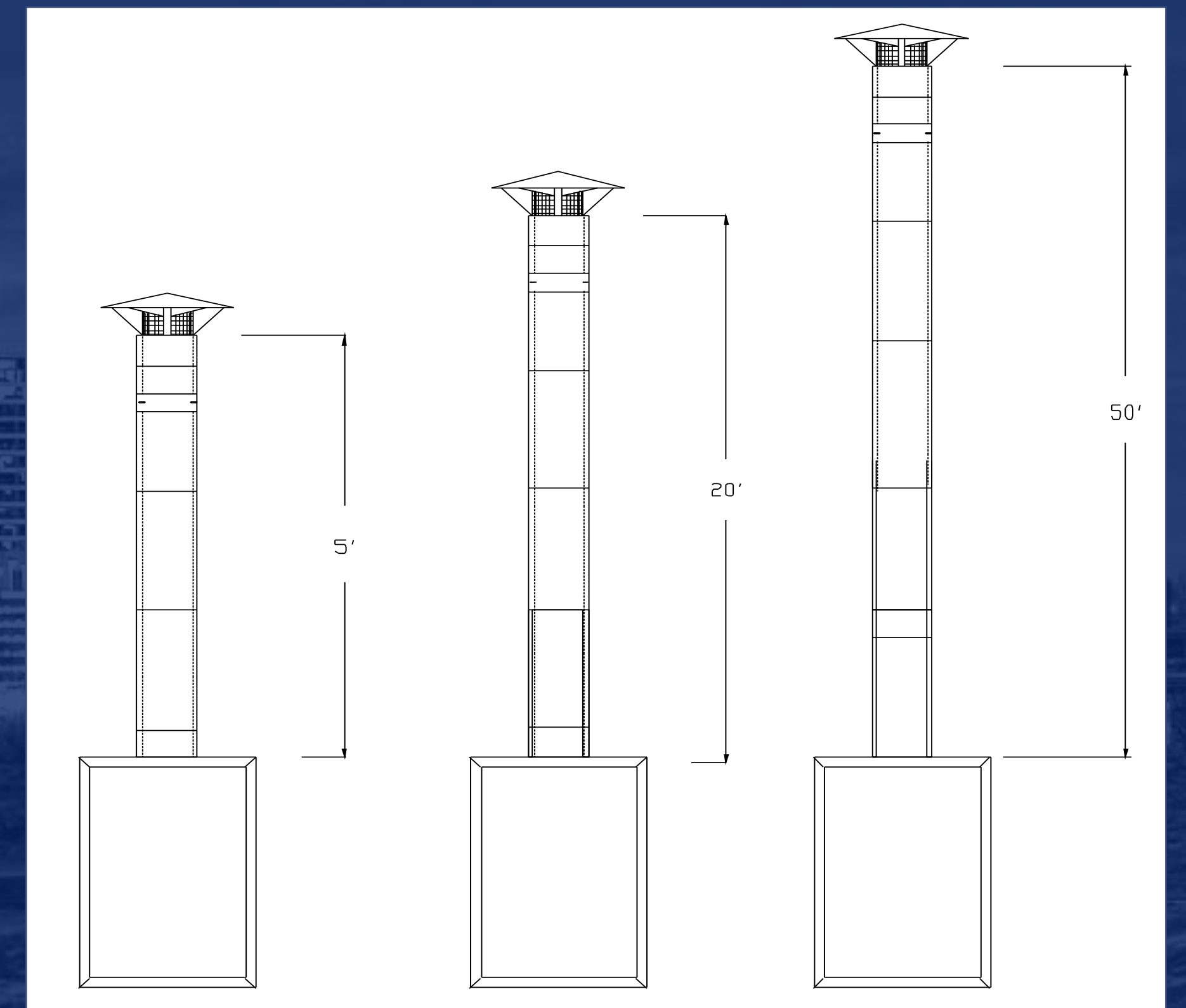

Barometric Dampers

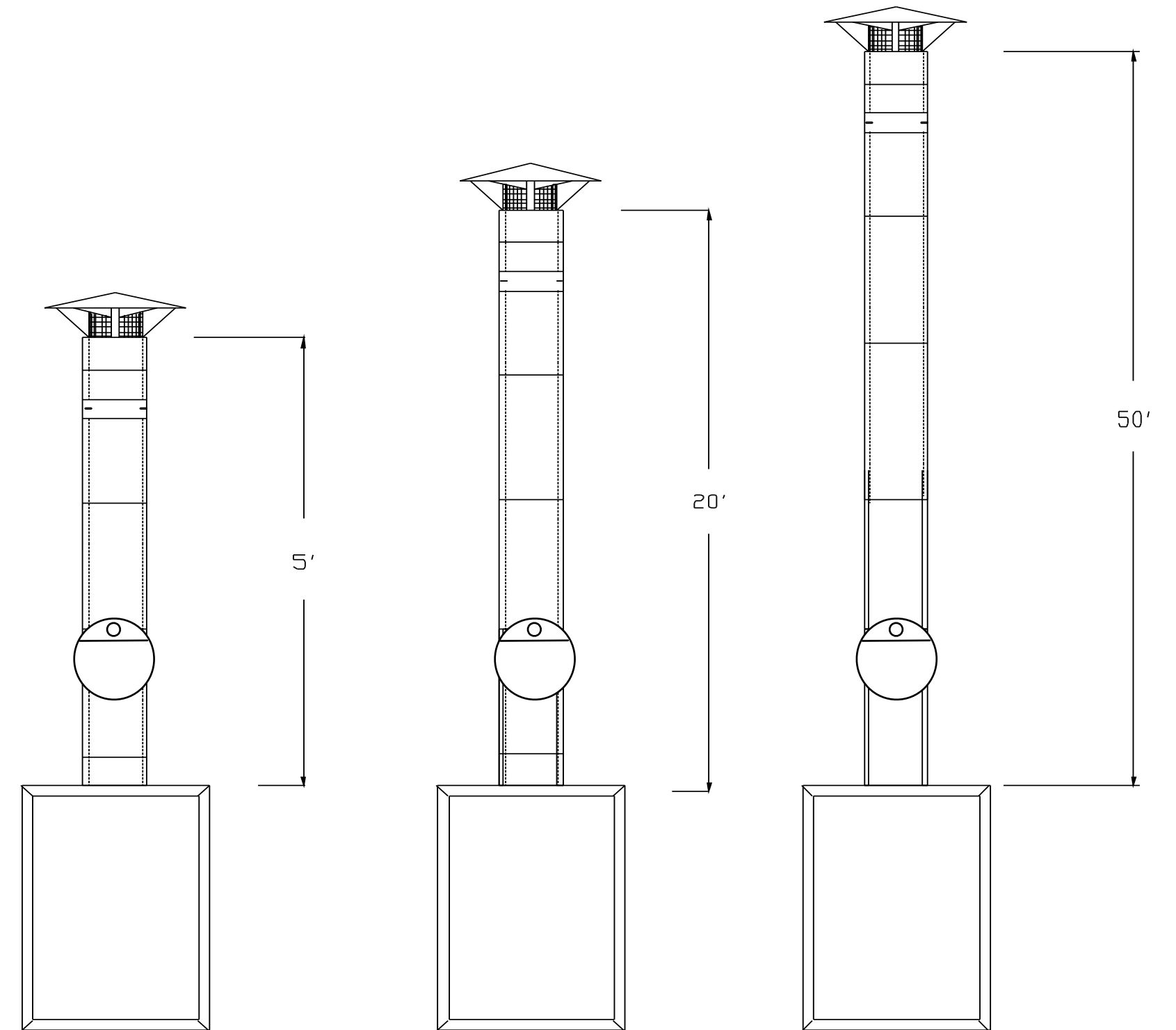

Variations of Draft, Common Vent

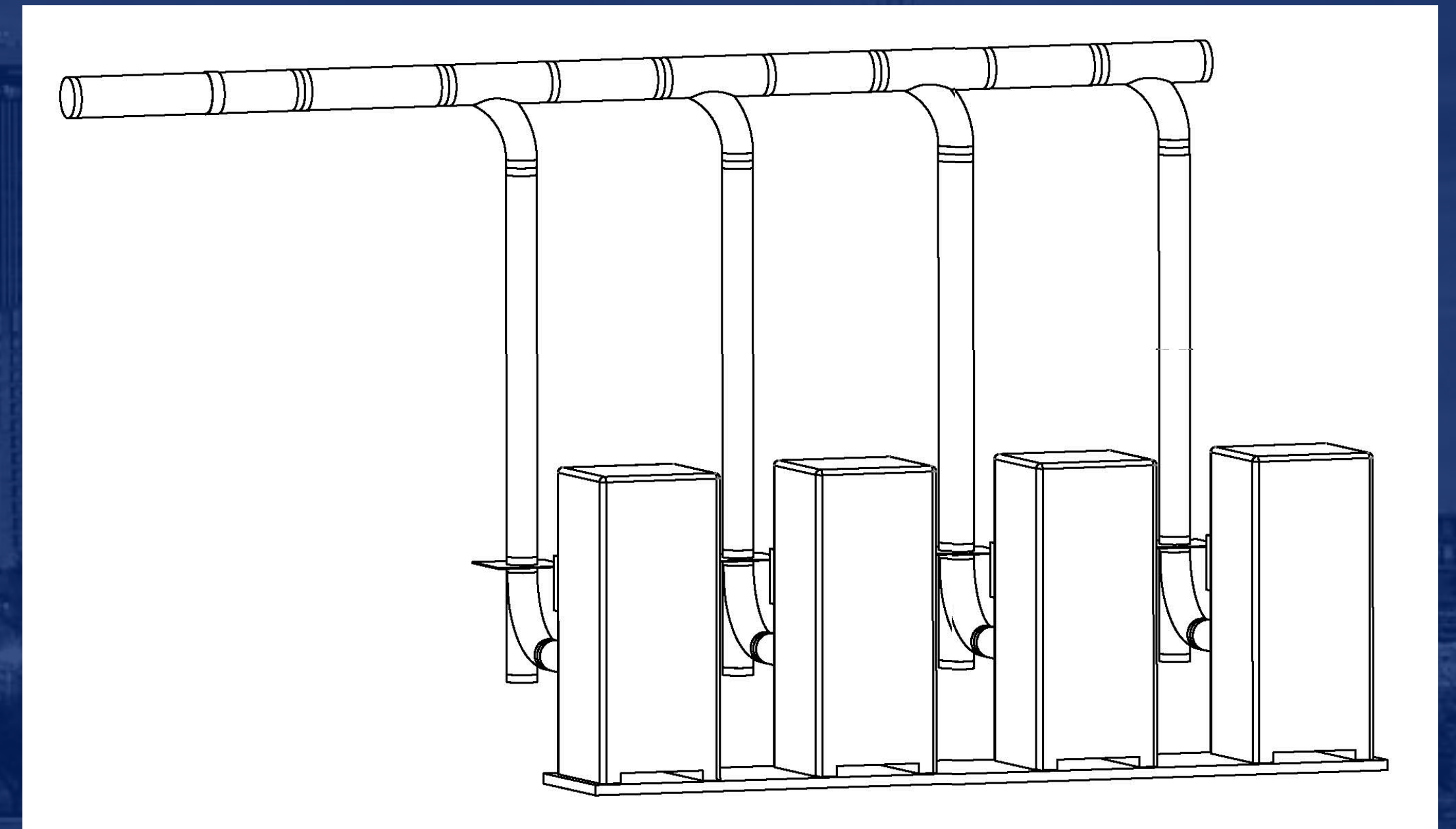
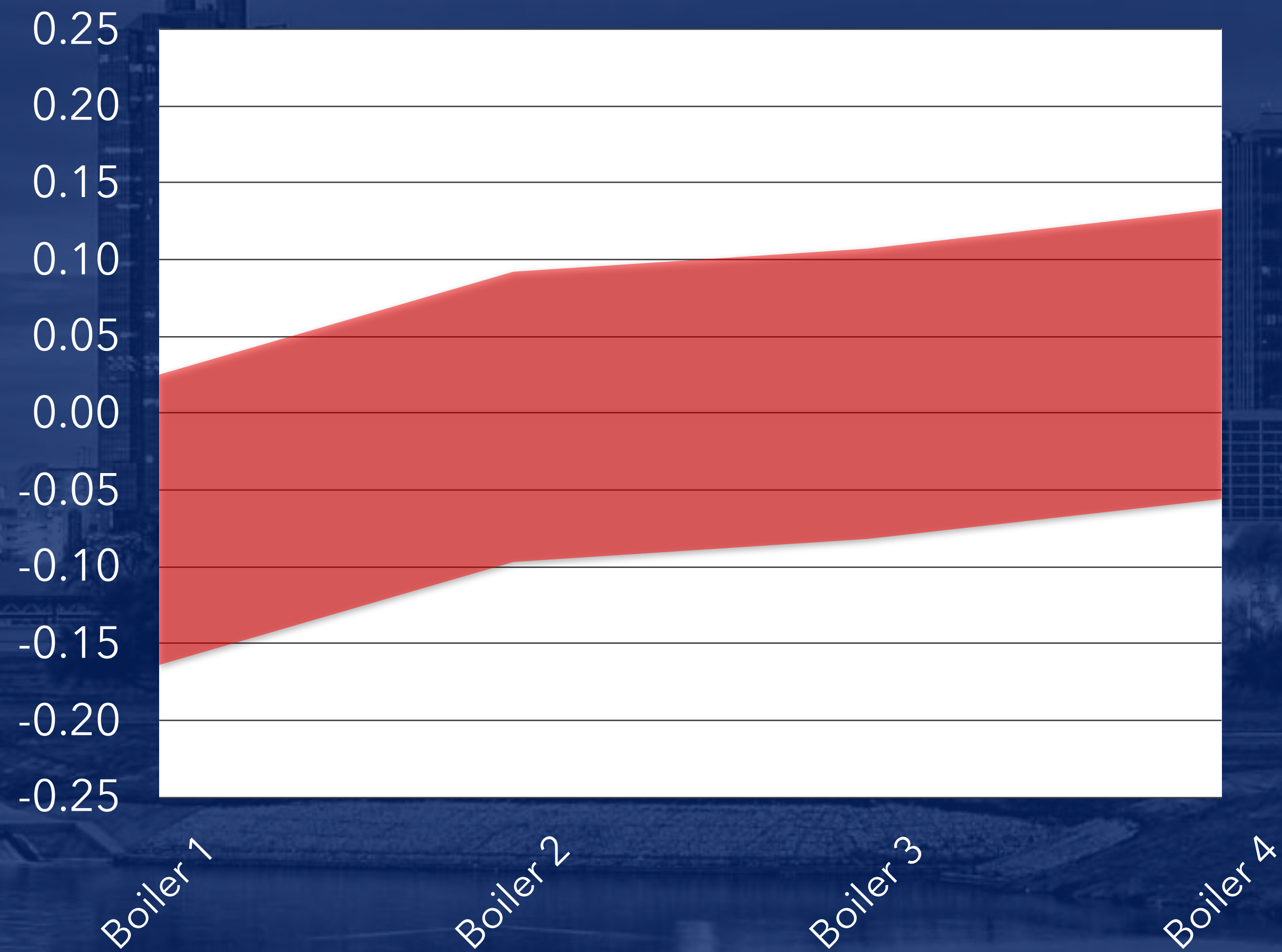

Variations of Draft, Common Vent

Category I

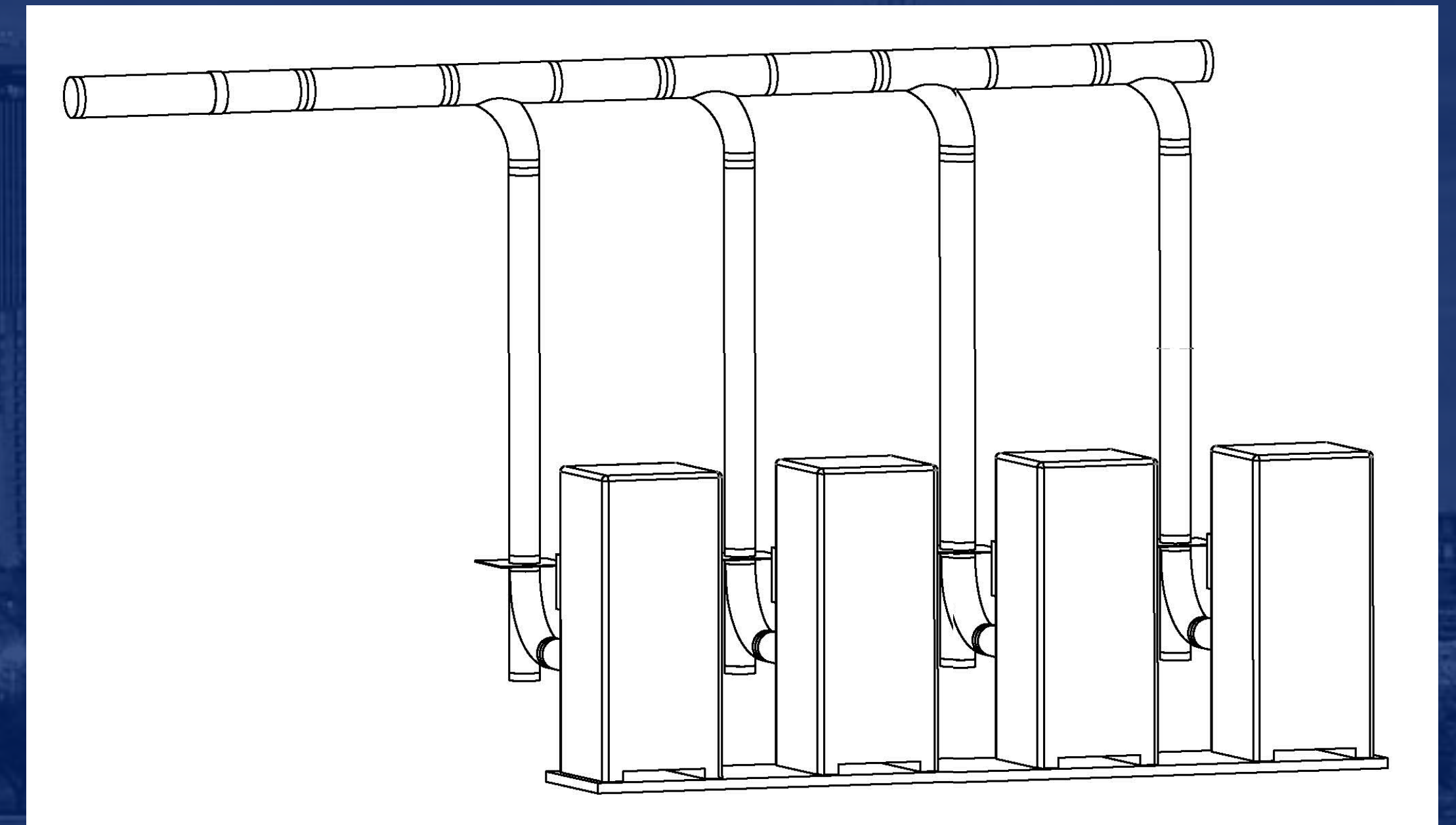
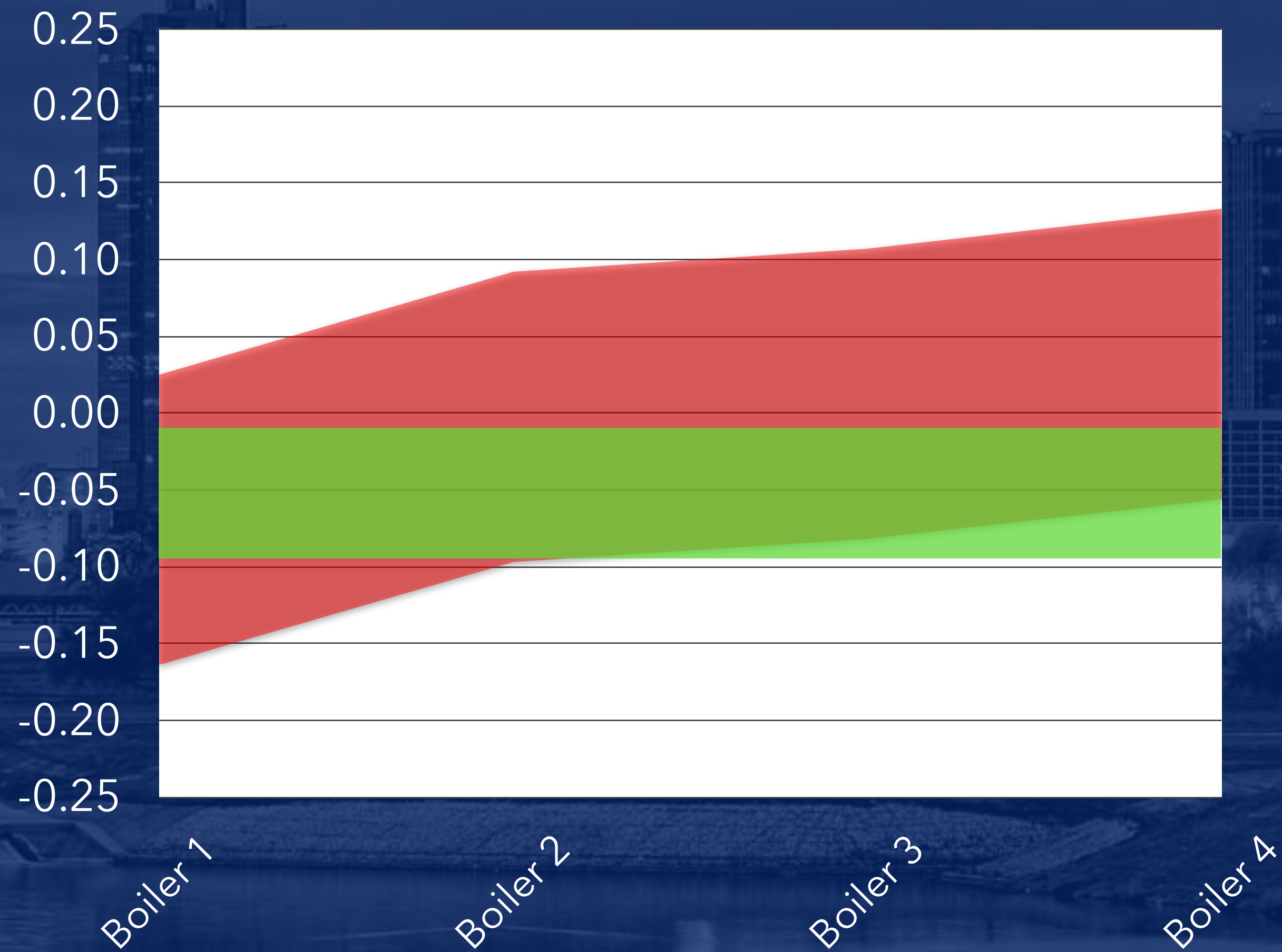



Variations of Draft, Common Vent

Category II & IV

Manufacturer A:
-0.25" / +0.25" w.c.

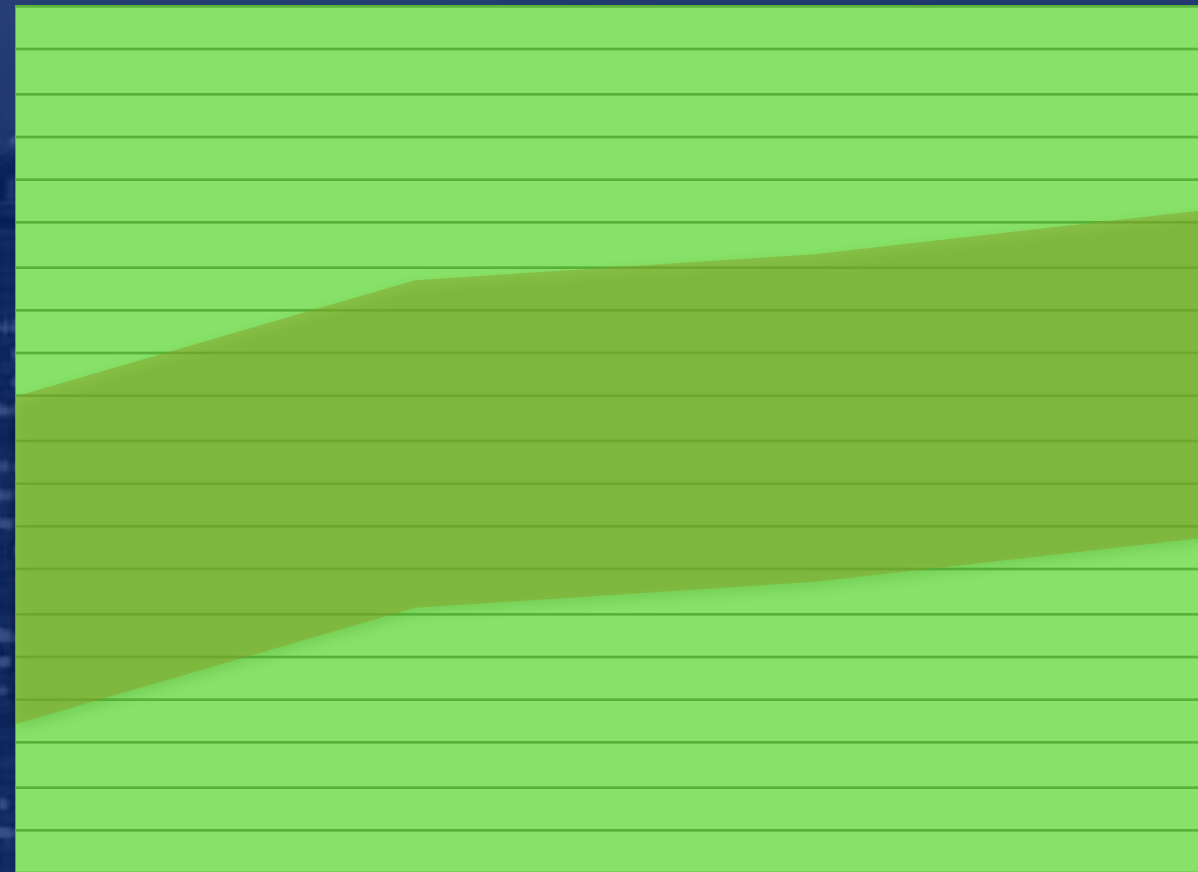

Manufacturer B:
-0.25" / +0.50" w.c.

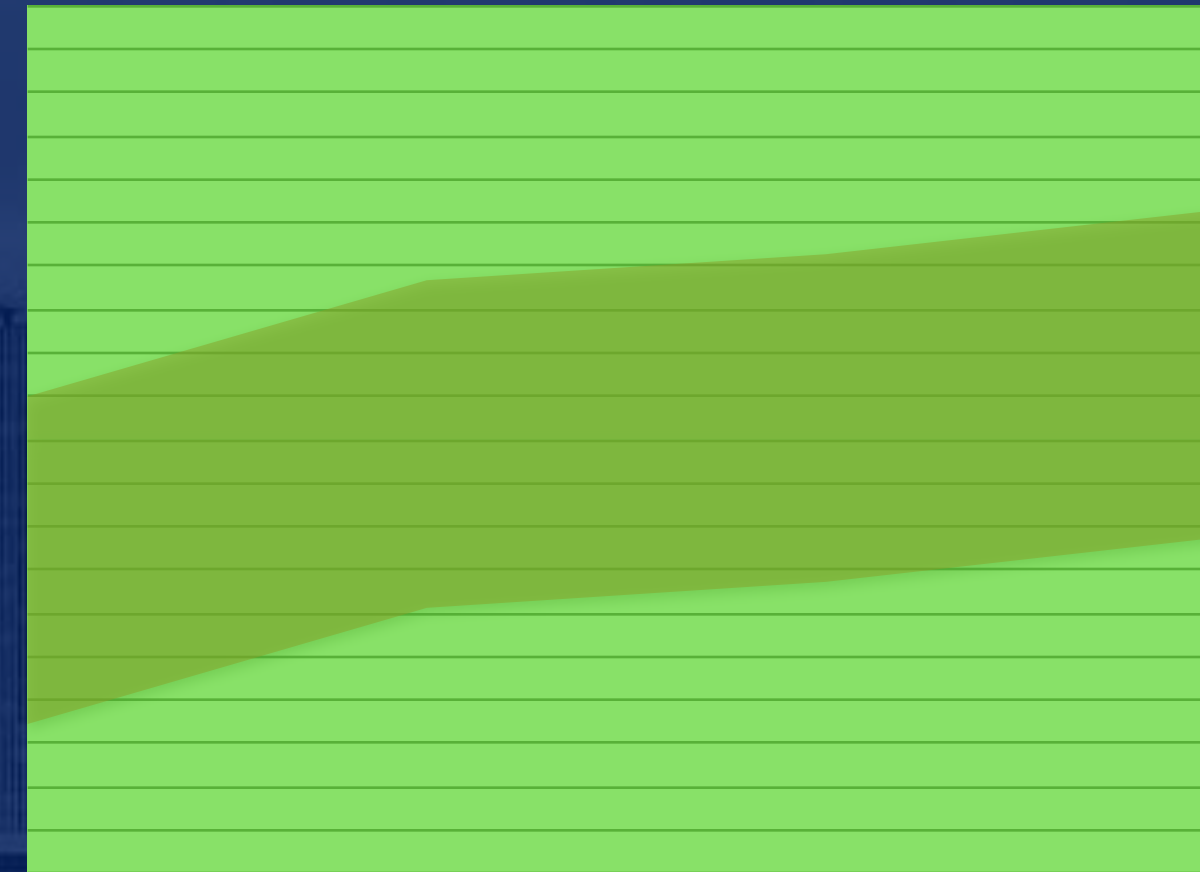

Manufacturer C:
-0.10" / +1.25" w.c.

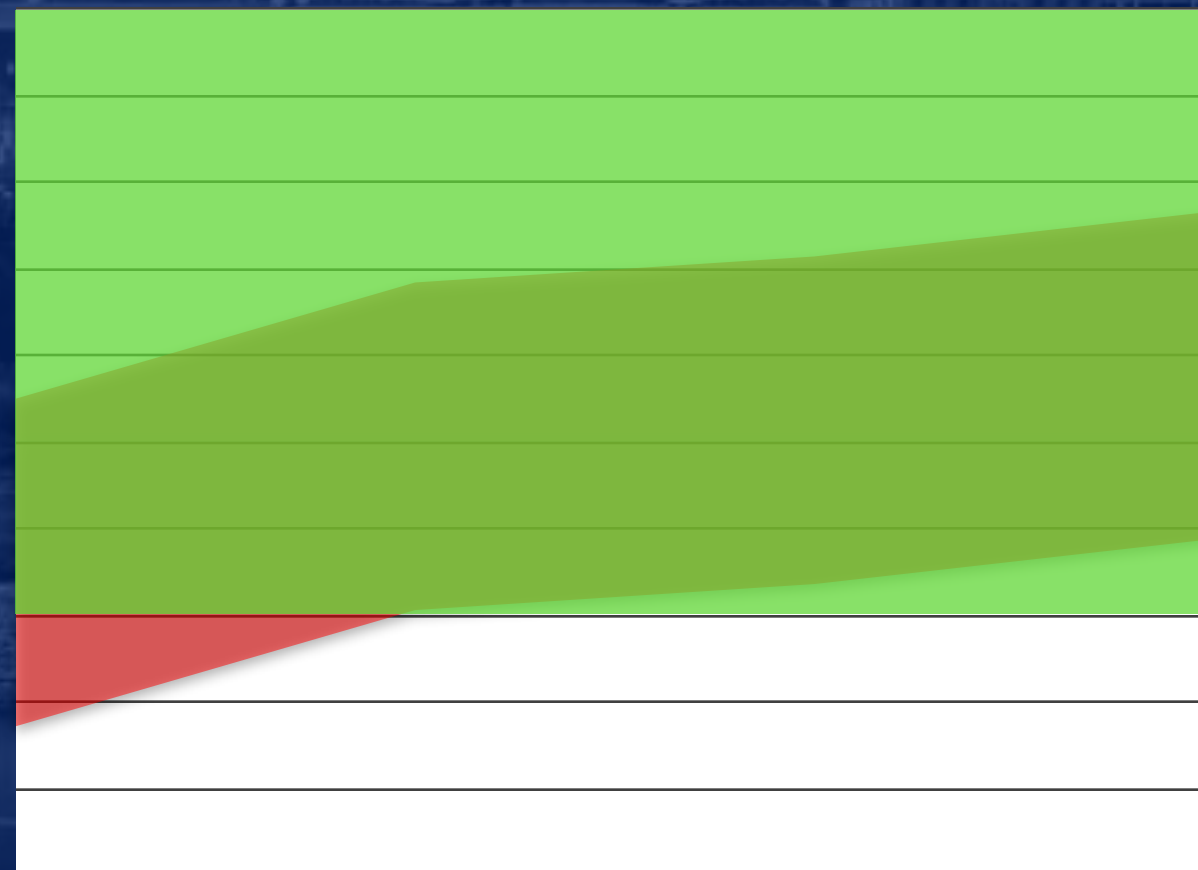

Manufacturer D:
-0.10" / 0.00" w.c.

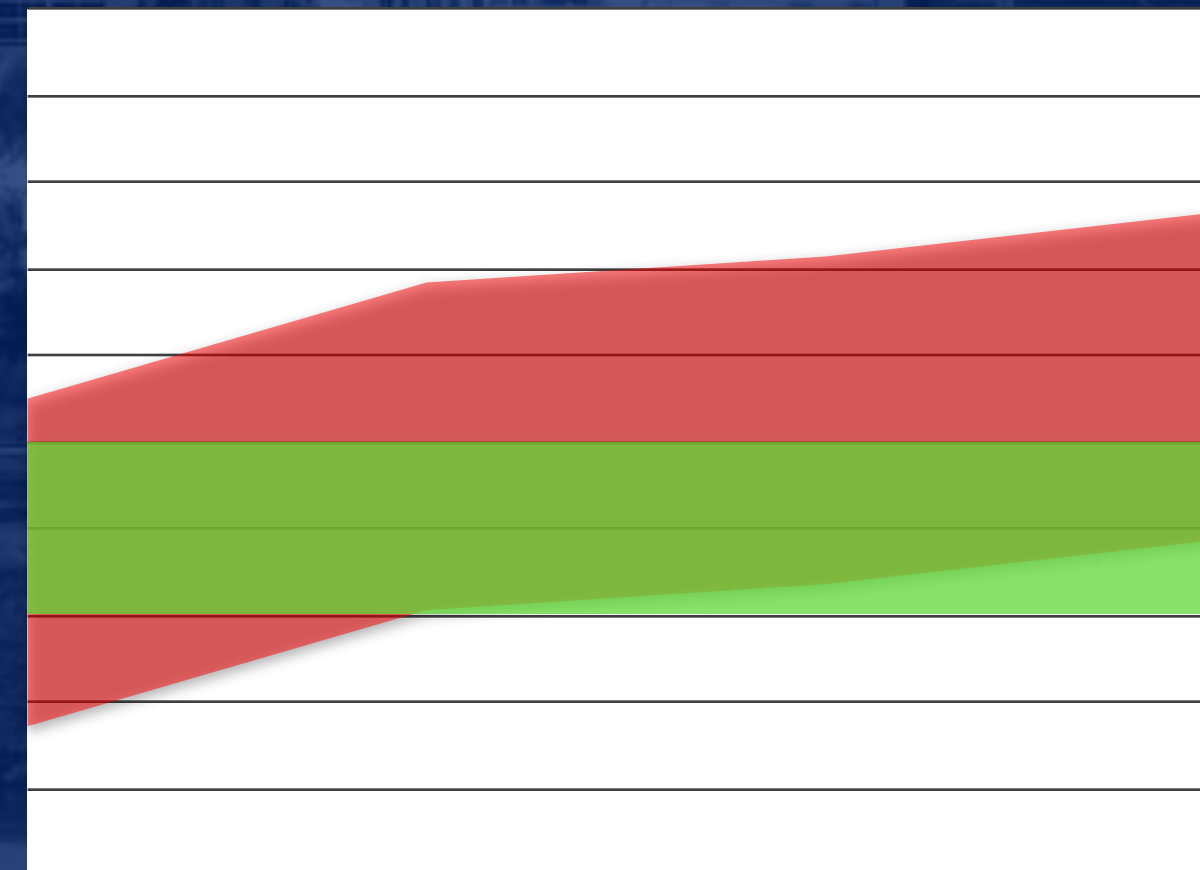

Typical Mechanical Draft System

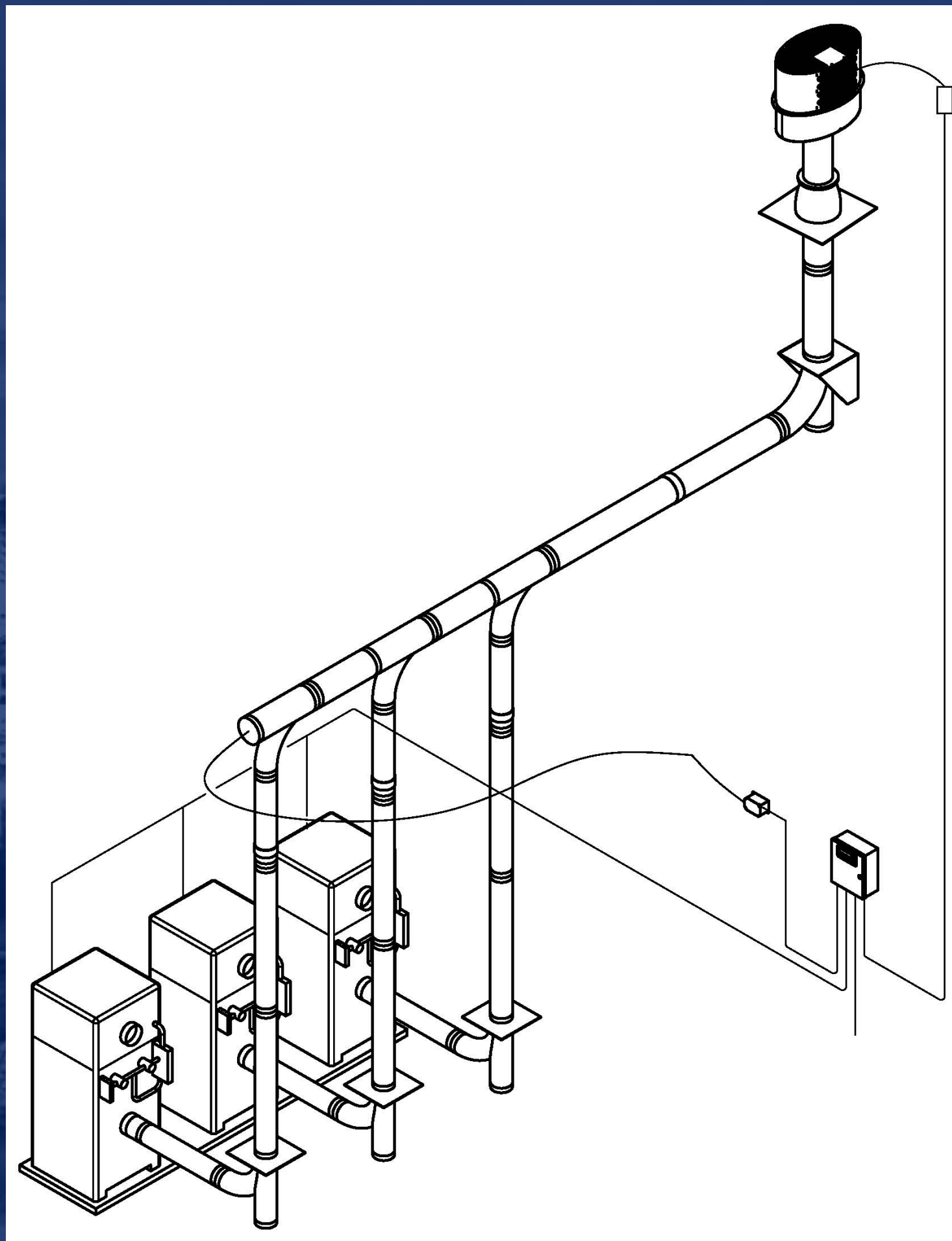

Typical Mechanical Draft System

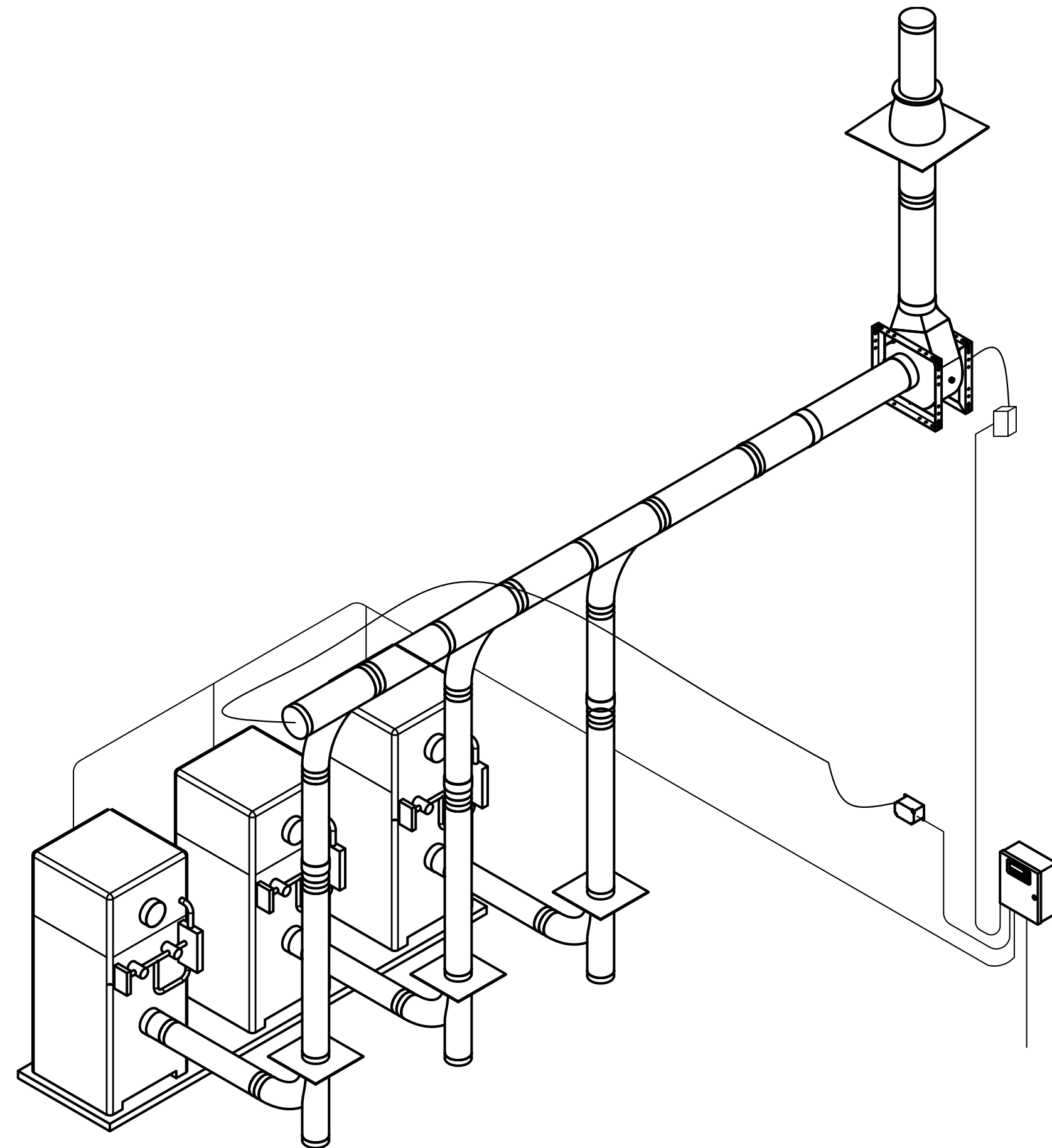

Typical Mechanical Draft System

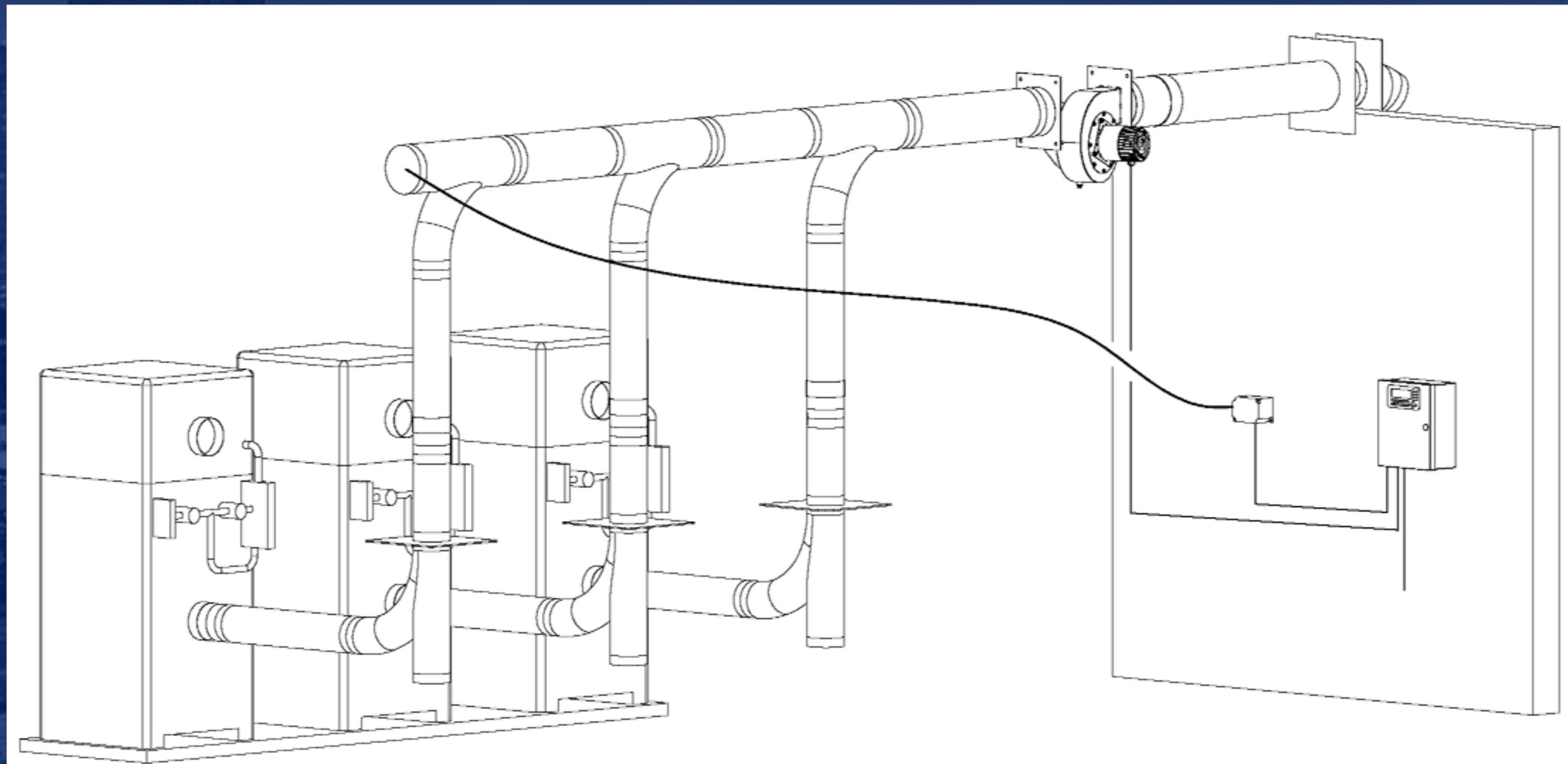

Variations of Draft, Common Vent

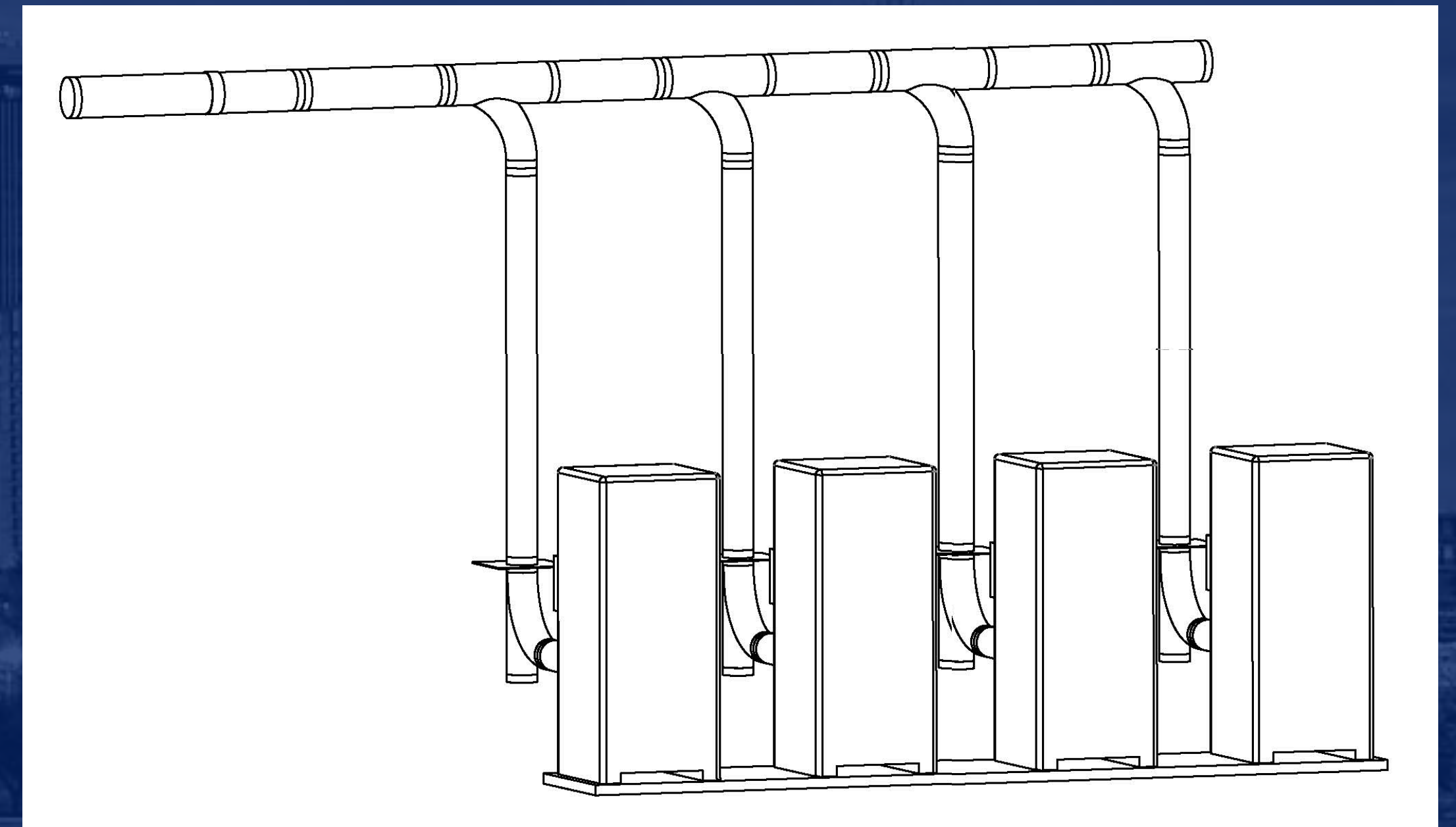
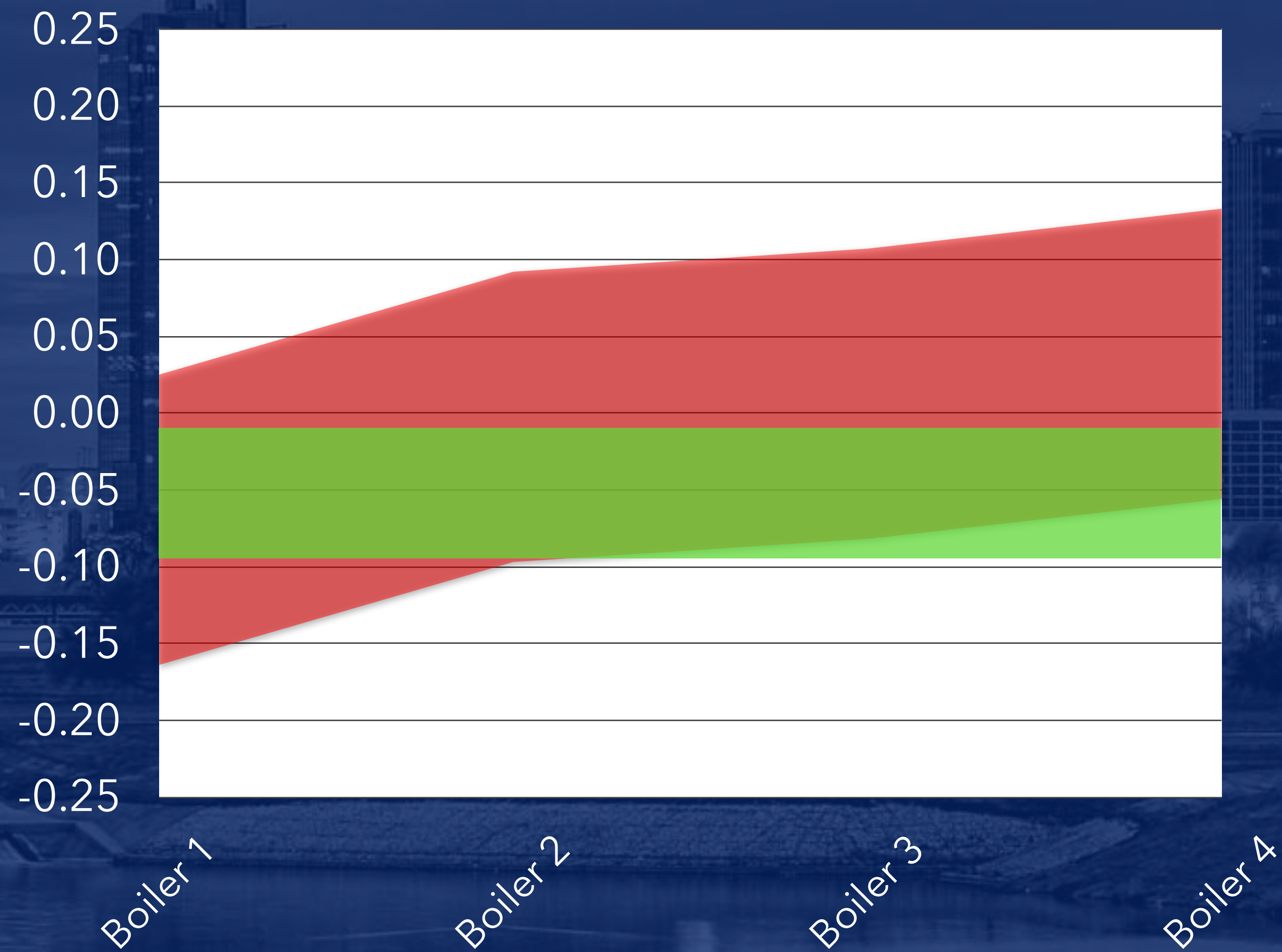

EC Flow Technology™

Existing Control Technology

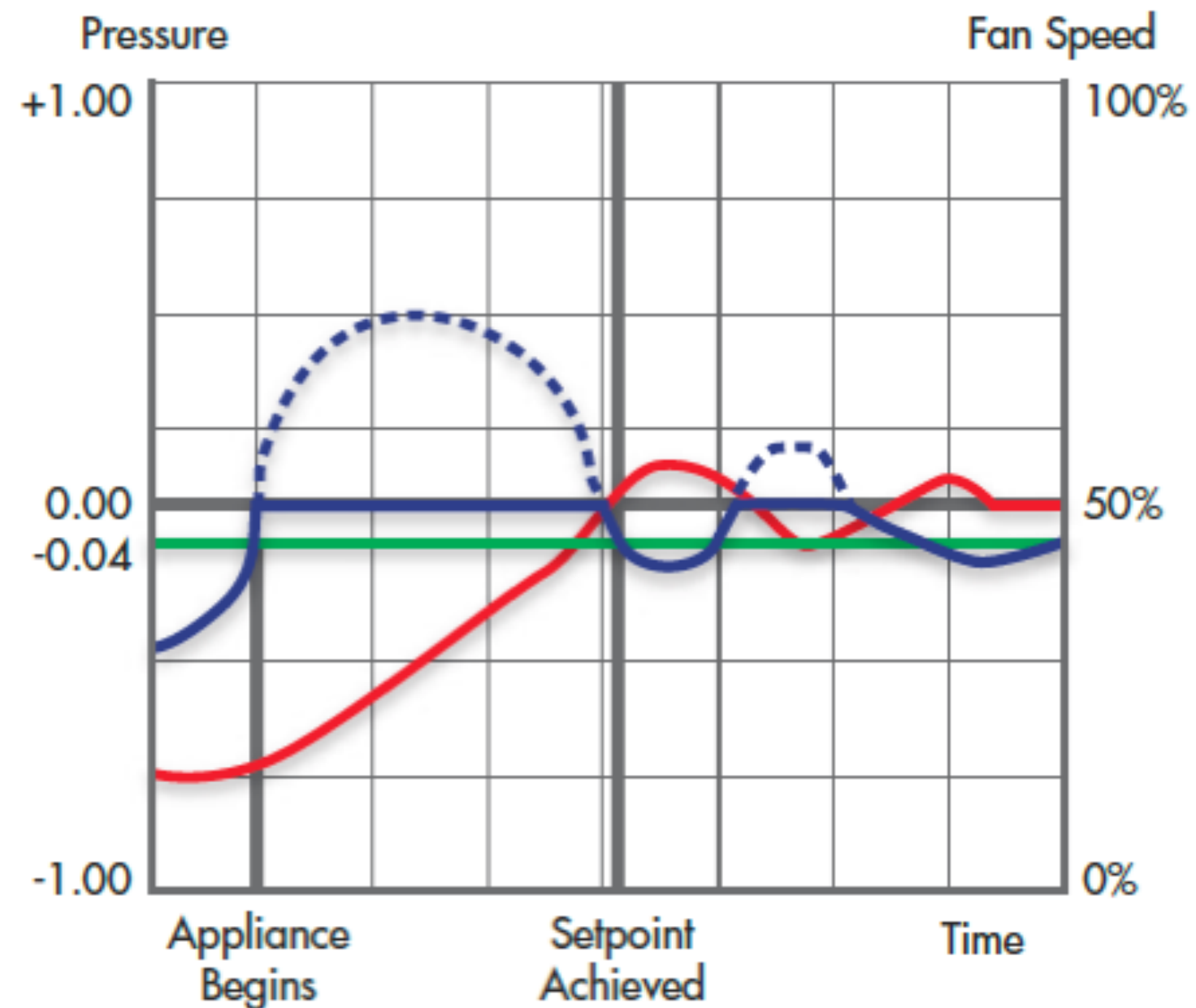

EC Flow Technology™

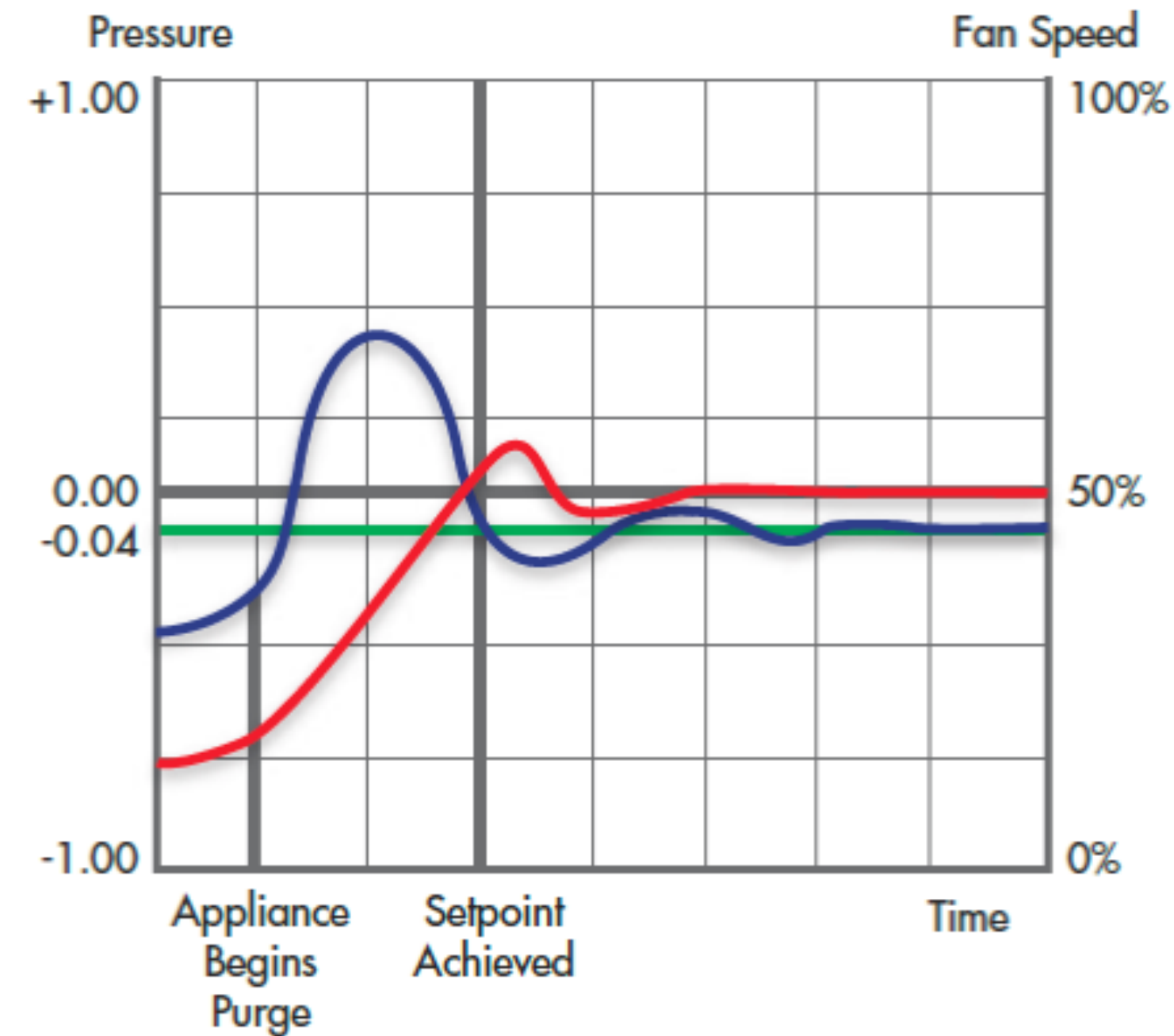

- Setpoint
- Pressure Reading
- Fan Speed
- Actual Pressure

Common Code Violations

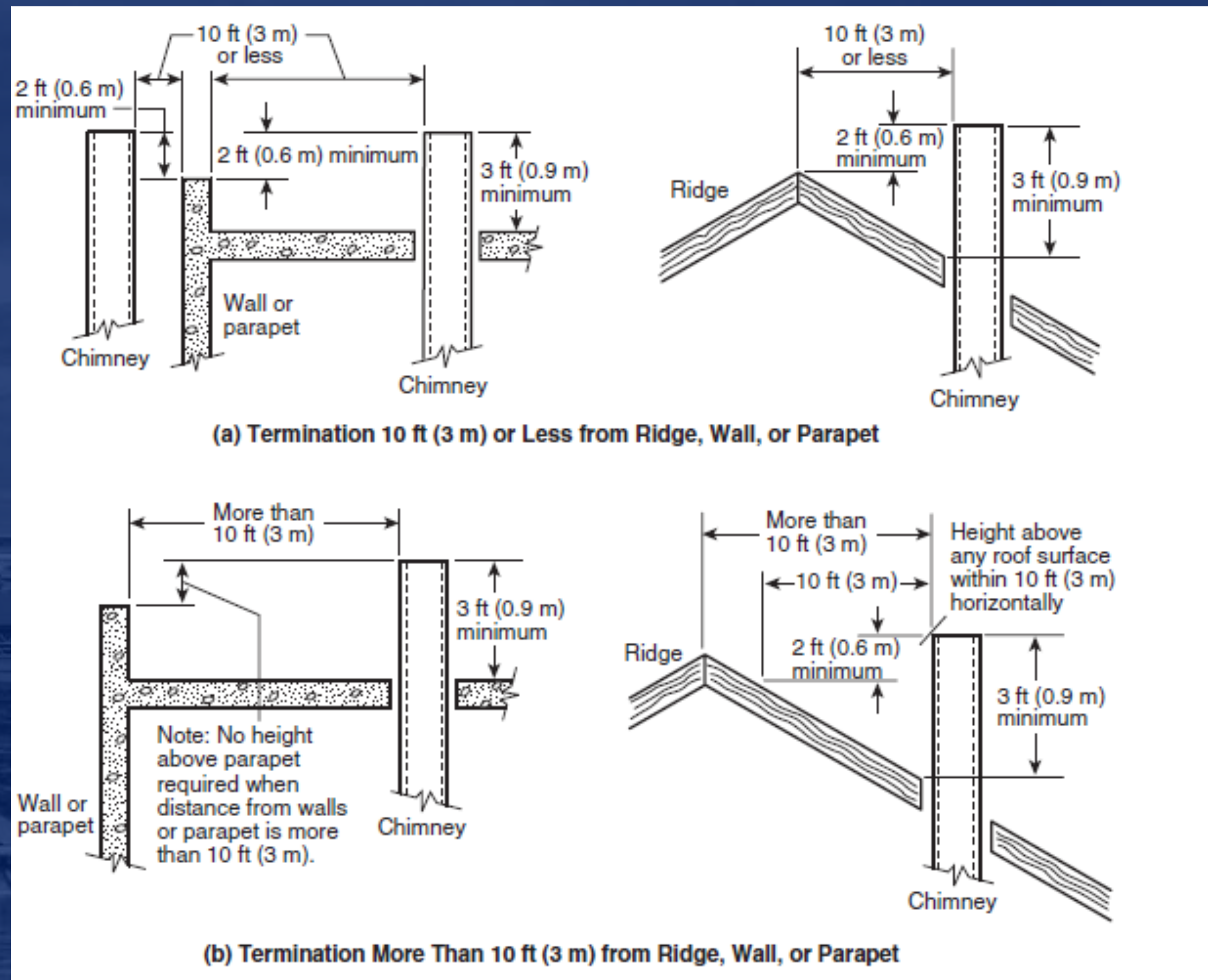

12.7.2 Gas Vent Termination. The termination of gas vents shall comply with the following requirements:

- (1) A gas vent shall terminate in accordance with one of the following:
 - (a) Gas vents that are 12 in. (300 mm) or less in size and located not less than 8 ft from a vertical wall or similar obstruction shall terminate above the roof in accordance with Figure 12.7.2 and Table 12.7.2.
 - (b) Gas vents that are over 12 in. in size or are located less than 8 ft from a vertical wall or similar obstruction shall terminate not less than 2 ft above the highest point where they pass through the roof and *not less than 2 ft (0.6 m) above any portion of a building within 10 ft (3.0 m) horizontally.*

Common Code Violations



Lower Terminations with Draft Inducer

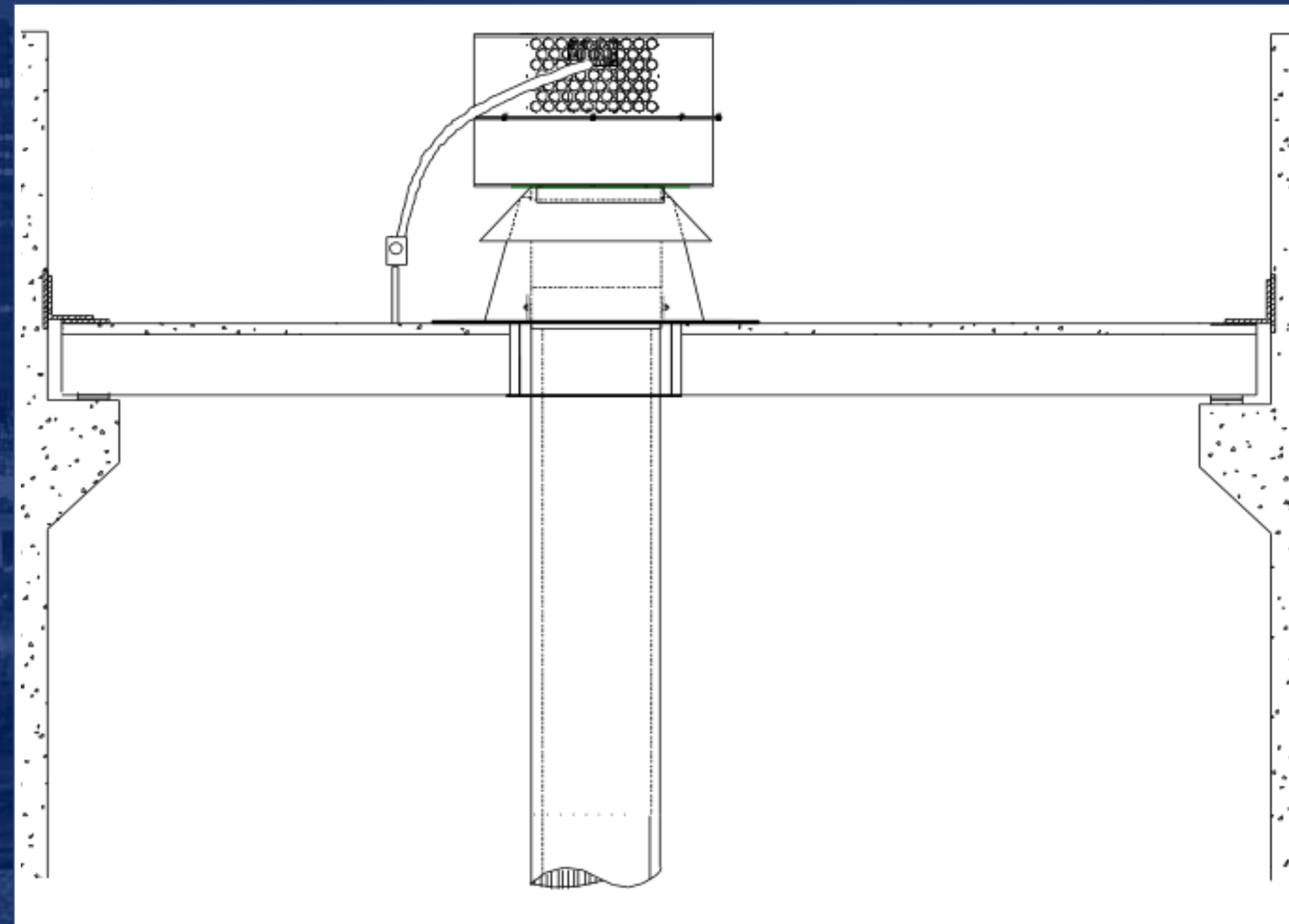

Common Code Violations



13.1.9 Vertical Vent Upsizing/7 × Rule. Where the vertical vent has a larger diameter than the vent connector, the vertical vent diameter shall be used to determine the minimum vent capacity, and the connector diameter shall be used to determine the maximum vent capacity. The flow area of the vertical vent shall not exceed seven times the flow area of the listed appliance categorized vent area, flue collar area, or draft hood outlet area unless designed in accordance with approved engineering methods.



Common Code Violations



12.4.3.3 Forced draft systems and all portions of induced draft systems under positive pressure during operation shall be designed and installed so as to prevent leakage of flue or vent gases into a building.

12.4.3.4 Vent connectors serving appliances vented by natural draft shall not be connected into any portion of mechanical draft systems operating under positive pressure.



Common Venting - Good Practices

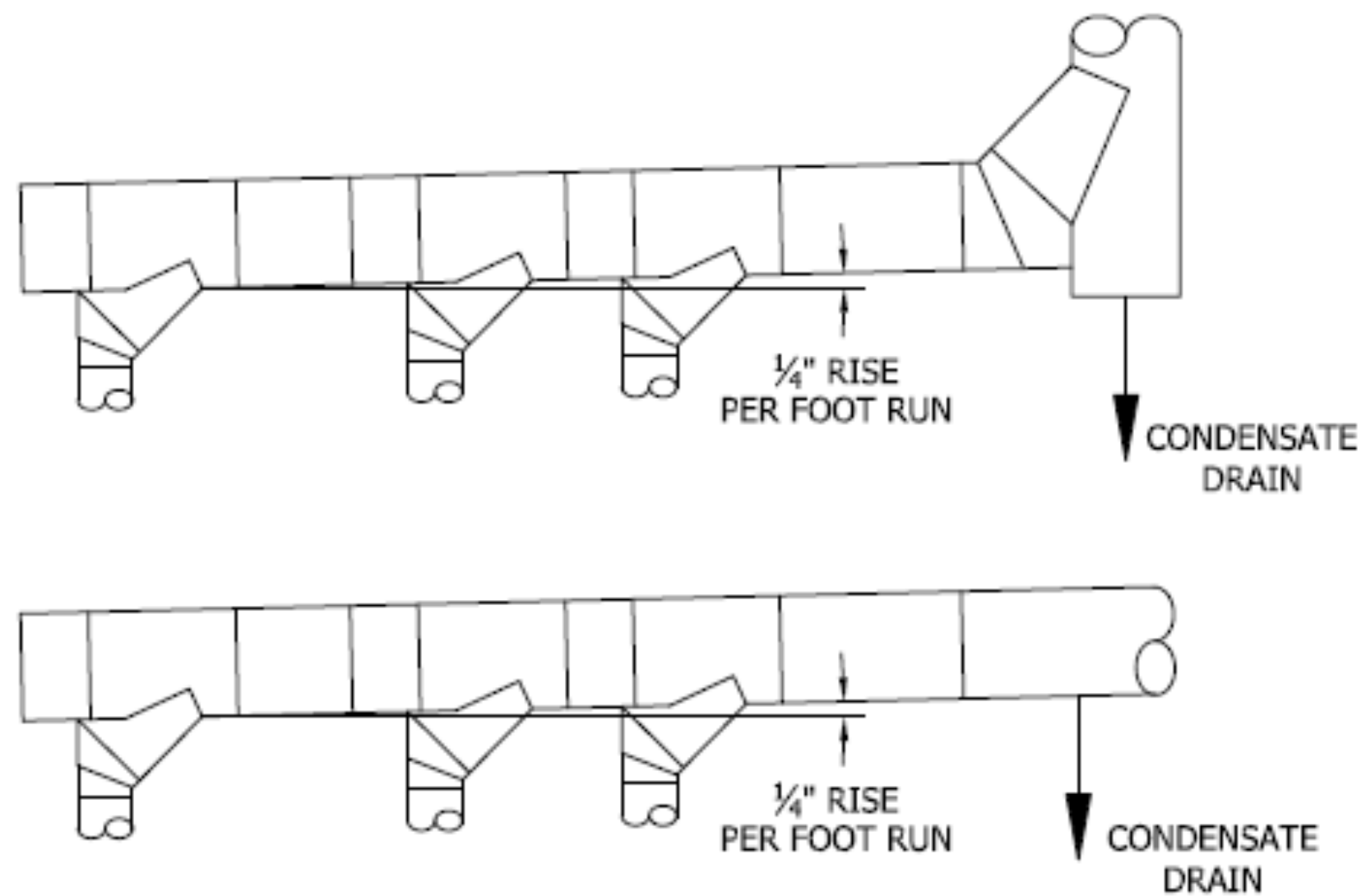

a. Recommended

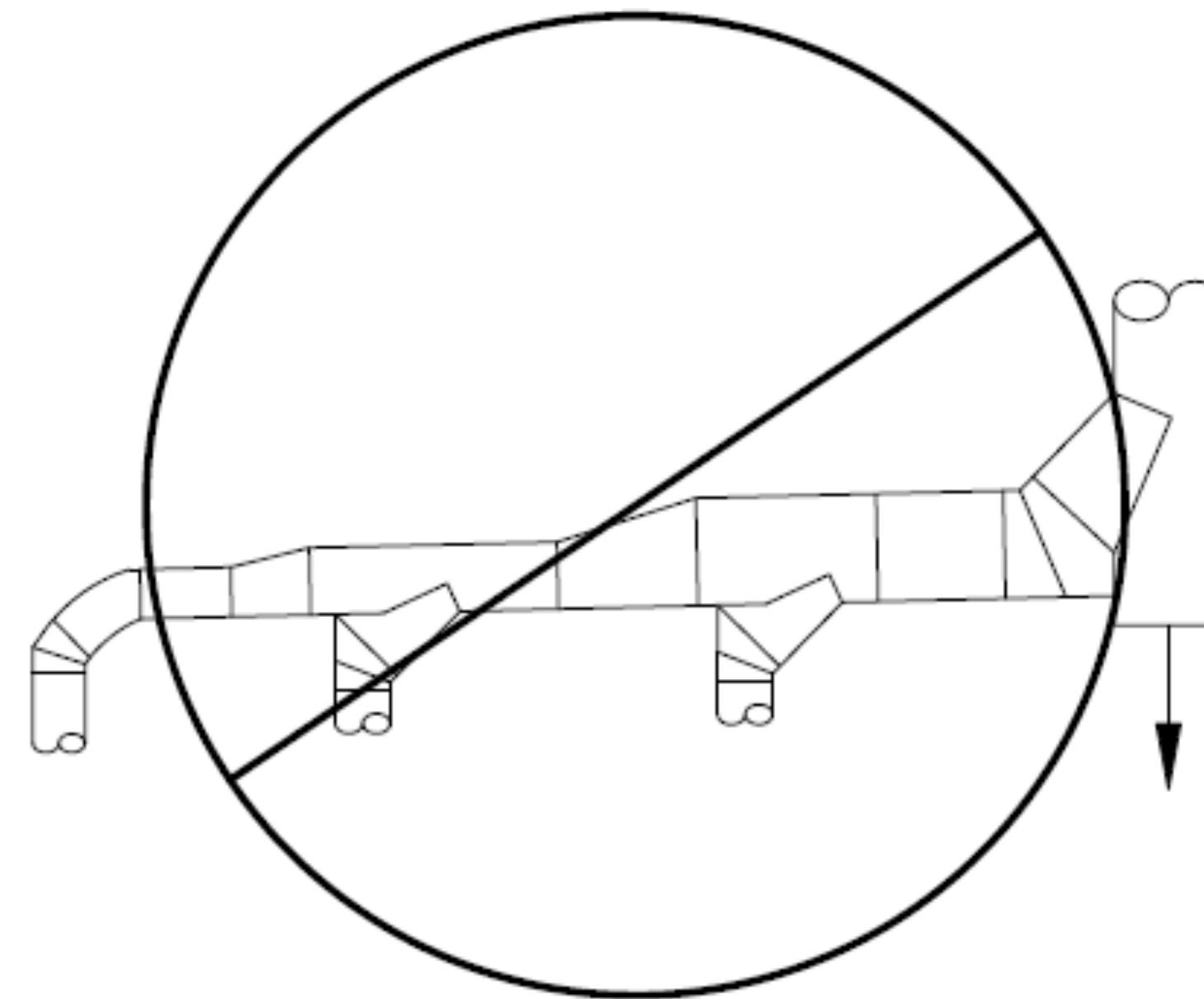

b. Static Regain method
Not Recommended

Common Venting - Good Practices

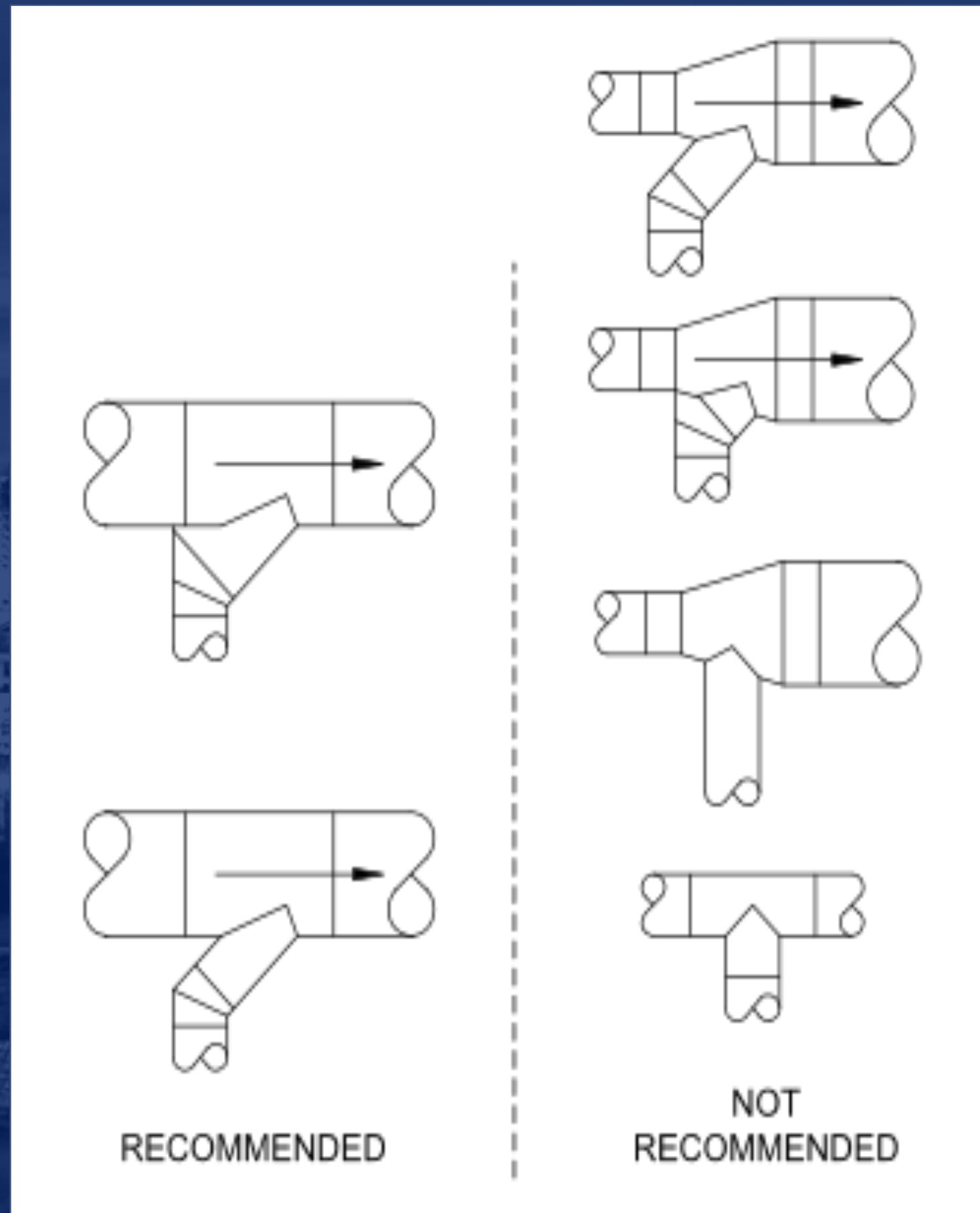

Overdraft



Effect of Chimney Height vs Outdoor Temp



Manufacturer A:
-0.25" / +0.25" w.c.

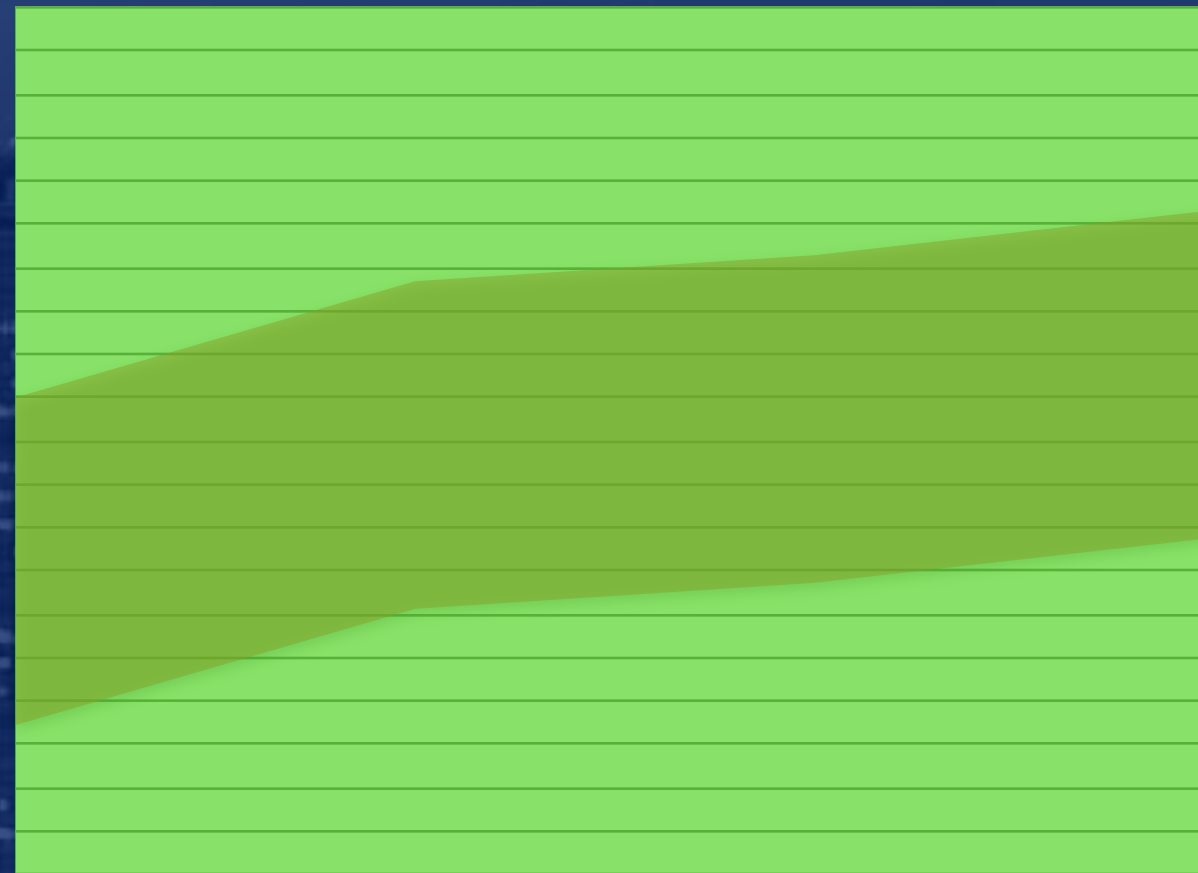

Manufacturer B:
-0.25" / +0.50" w.c.

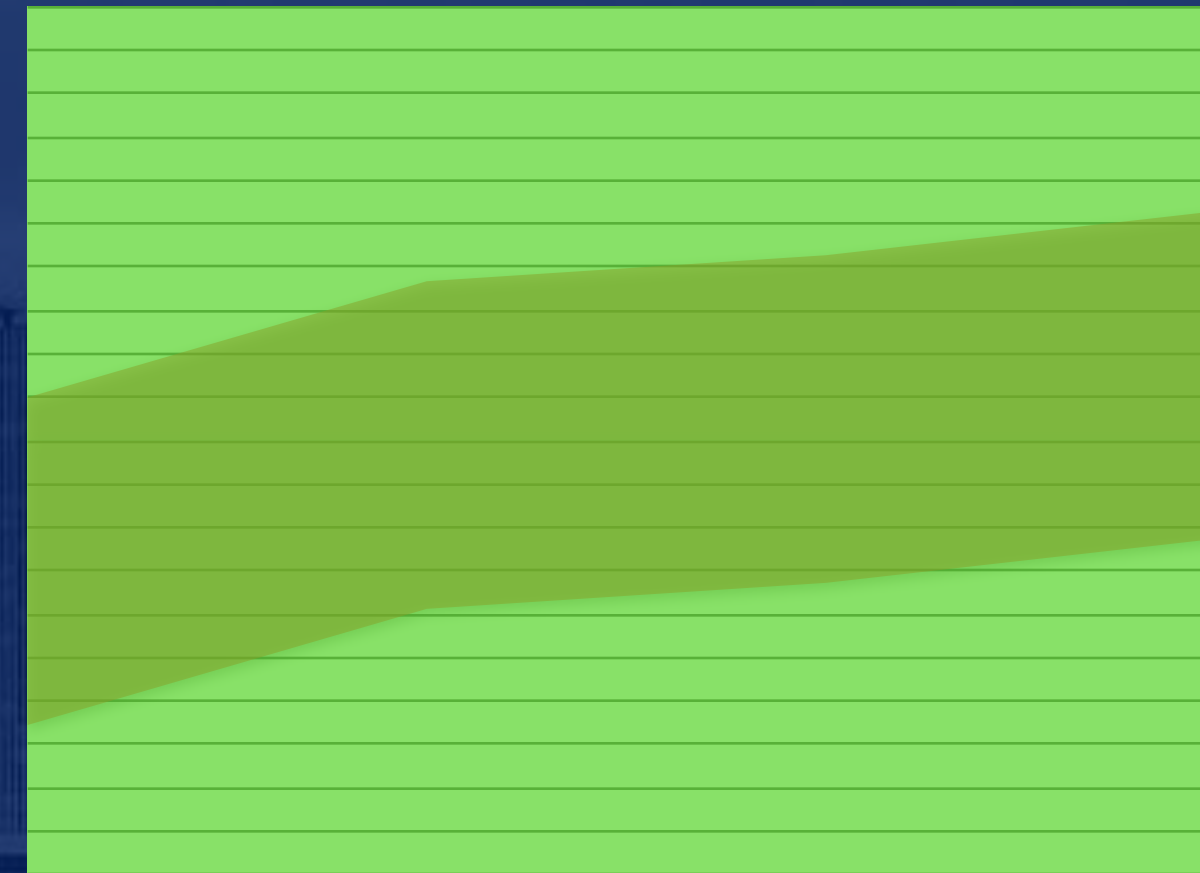

Manufacturer C:
-0.10" / +1.25" w.c.

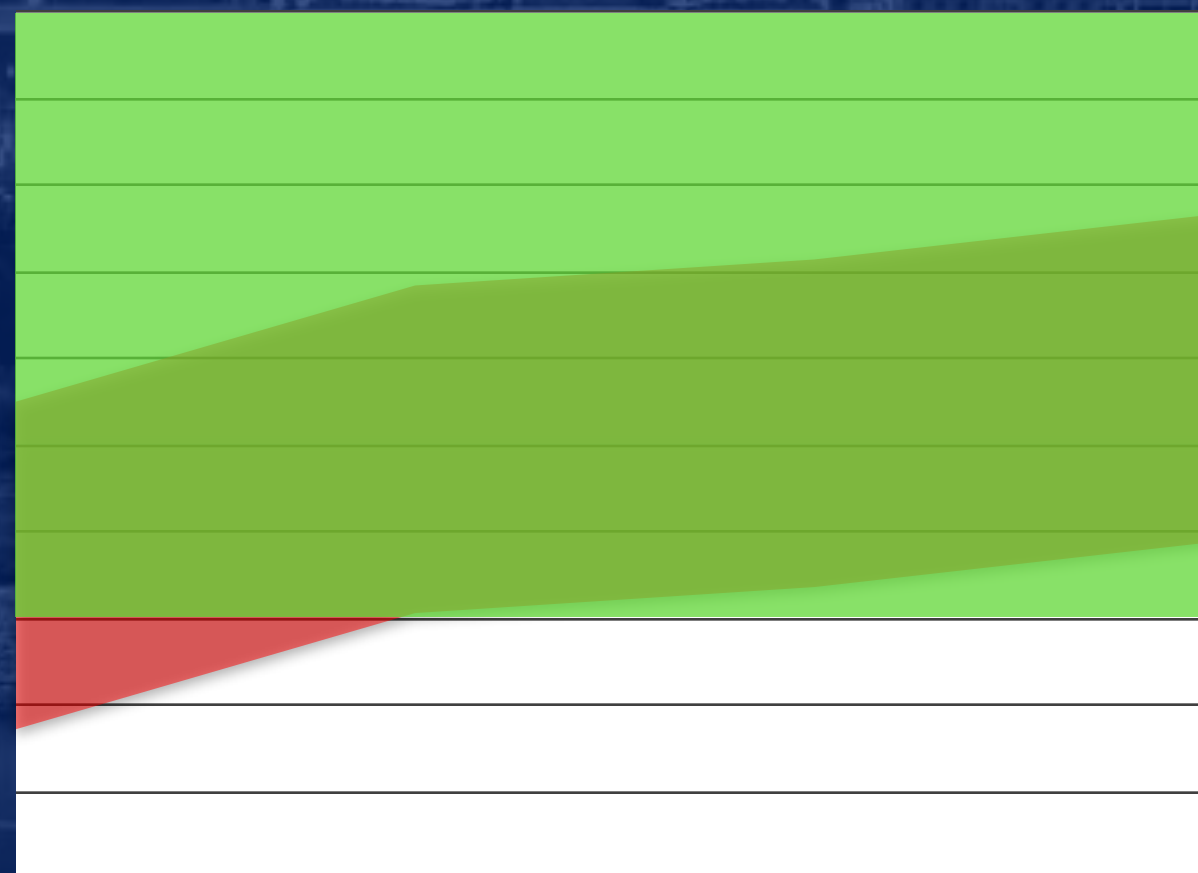

Manufacturer D:
-0.10" / 0.00" w.c.



Typical Mechanical Draft System

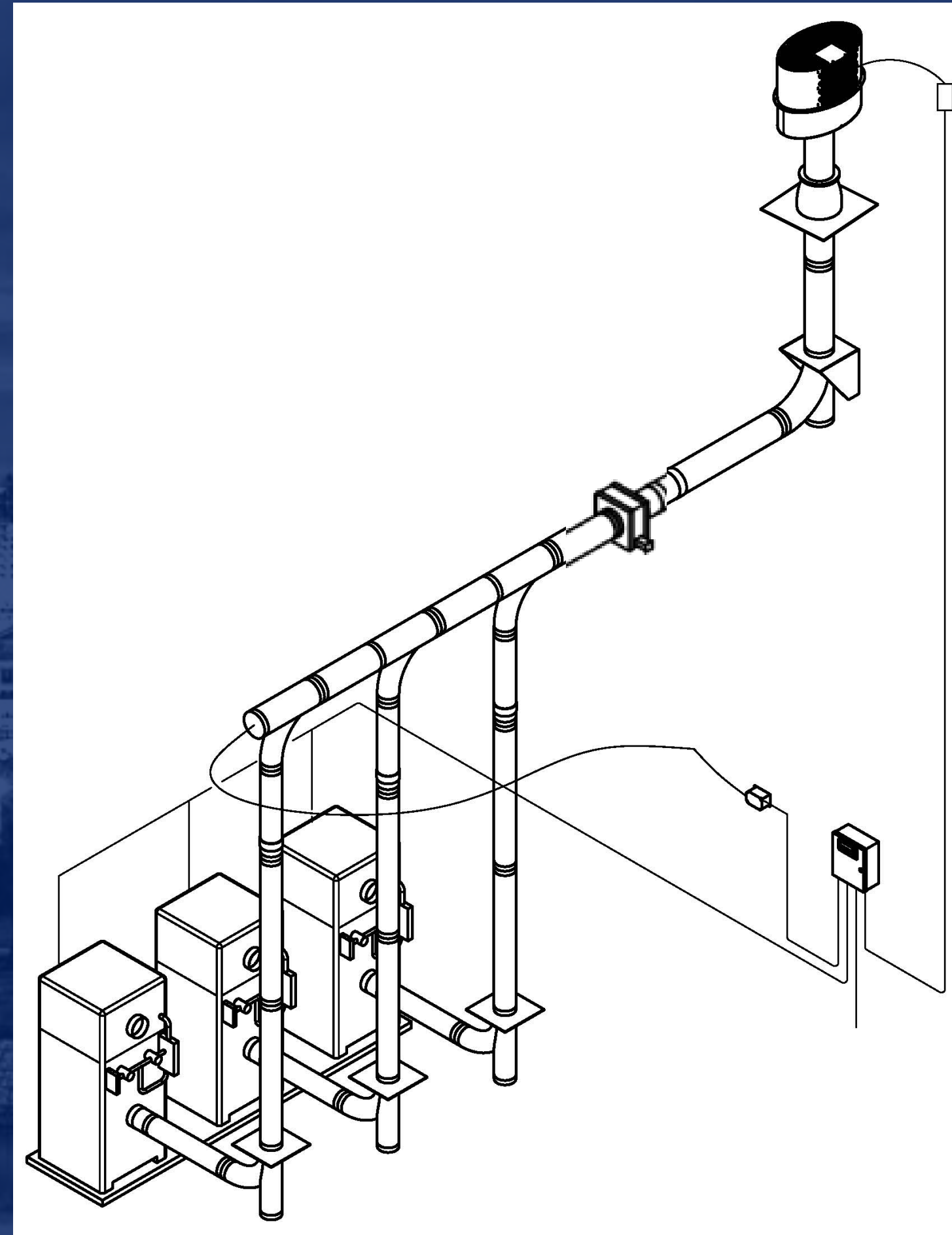

Concerns of Mechanical Draft



1. Cost

Concerns of Mechanical Draft

1. Cost

In most cases, equipment costs can be offset by less vent material and smaller diameters

Concerns of Mechanical Draft

1. Cost
 2. Complication
- 

Concerns of Mechanical Draft

1. Cost

2. Complication

In most cases, equipment manufacturers work together to minimize complications

Concerns of Mechanical Draft

1. Cost
2. Complication
3. Single Point of Failure

Concerns of Mechanical Draft

1. Cost
2. Complication
3. Single Point of Failure

Redundancy systems can be designed to prevent single failure point

Individual Connector Draft System

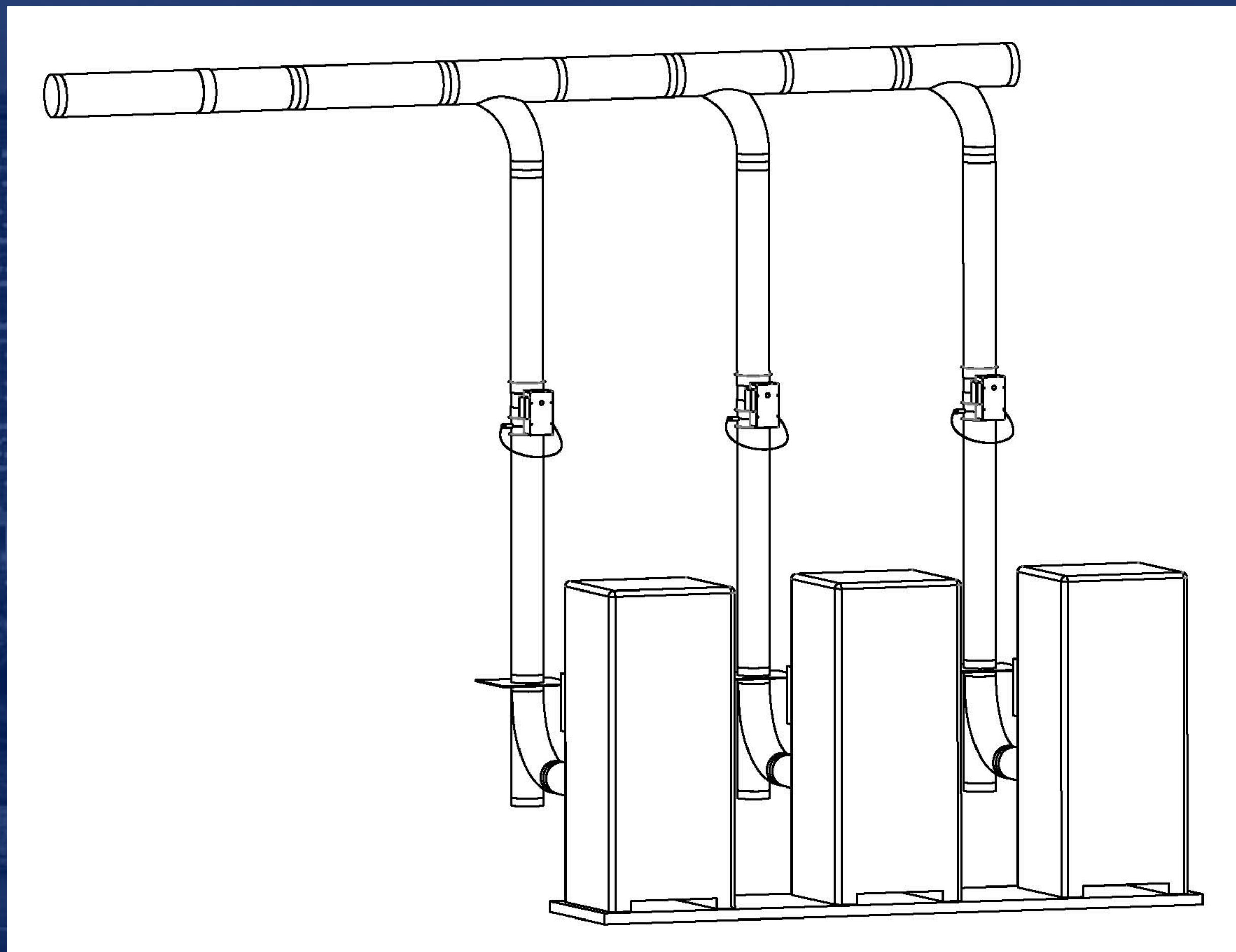

Thank You!
Questions and Comments

